

# QFX5241-320D Switch Hardware Guide

Published  
2026-01-19

Juniper Networks, Inc.  
1133 Innovation Way  
Sunnyvale, California 94089  
USA  
408-745-2000  
www.juniper.net

Juniper Networks, the Juniper Networks logo, Juniper, and Junos are registered trademarks of Juniper Networks, Inc. in the United States and other countries. All other trademarks, service marks, registered marks, or registered service marks are the property of their respective owners.

Juniper Networks assumes no responsibility for any inaccuracies in this document. Juniper Networks reserves the right to change, modify, transfer, or otherwise revise this publication without notice.

*QFX5241-320D Switch Hardware Guide*  
Copyright © 2026 Juniper Networks, Inc. All rights reserved.

The information in this document is current as of the date on the title page.

## YEAR 2000 NOTICE

Juniper Networks hardware and software products are Year 2000 compliant. Junos OS has no known time-related limitations through the year 2038. However, the NTP application is known to have some difficulty in the year 2036.

## END USER LICENSE AGREEMENT

The Juniper Networks product that is the subject of this technical documentation consists of (or is intended for use with) Juniper Networks software. Use of such software is subject to the terms and conditions of the End User License Agreement ("EULA") posted at <https://support.juniper.net/support/eula/>. By downloading, installing or using such software, you agree to the terms and conditions of that EULA.

# Table of Contents

About this Guide | vii

1

## Fast Track: Initial Installation

Fast Track to Rack Installation and Powering Connection | 2

Install the QFX5241-32OD Switch on a Square Hole Rack by Using the QFX5241-1U-4PRMK Rack Mount Kit | 2

Connect the QFX5241-32OD Switch to Power | 7

Ground the QFX5241-32OD Switch | 7

Connect AC Power to QFX5241-32OD Switch | 9

Onboard, Configure, and Monitor QFX5241-32OD Switch | 11

2

## Overview

QFX5241-32OD System Overview | 14

QFX5241-32OD Switch Description | 14

QFX5241-32OD Hardware Component Overview | 17

System Software | 18

QFX5241-32OD Component Redundancy | 18

QFX5241-32OD FRUs | 20

QFX5241-32OD Chassis Physical Specifications | 20

QFX5241-32OD Port Panel | 21

QFX5241-32OD Switch Management Panel | 24

QFX5241-32OD Management Panel | 24

QFX5241-32OD Management Panel LEDs | 25

QFX5241-32OD Power System | 32

QFX5241-32OD AC Power Supply Unit Description | 33

AC Power Cord Specifications | 34

QFX5241-32OD AC Power Supply Unit LED | 35

## **QFX5241-32OD Cooling System | 37**

| QFX5241-32OD Cooling System Description | 37

## **Site Planning, Preparation, and Specifications**

### **QFX5241-32OD Site Preparation Checklist | 43**

### **QFX5241-32OD Site Guidelines and Requirements | 44**

| QFX5241-32OD Environmental Requirements and Specifications | 45

General Site Guidelines | 46

QFX5241-32OD Grounding Cable and Lug Specifications | 46

QFX5241-32OD Clearance Requirements for Airflow and Hardware Maintenance | 48

Site Electrical Wiring Guidelines | 48

| QFX5241-32OD Rack Requirements | 50

### **QFX5241-32OD Network Cables and Transceivers Planning | 52**

Determine QFX5241-32OD Switch Optical Interface Support | 52

Understand QFX Series Fiber-Optic Cable Signal Loss, Attenuation, and Dispersion | 53

Calculate Power Budget and Power Margin for Fiber-Optic Cables | 54

| Calculate Power Budget for Fiber-Optic Cables | 55

| How to Calculate Power Margin for Fiber-Optic Cables | 55

### **QFX5241-32OD Management Cable Specifications and Pinouts | 57**

| Cable Specifications for Console and Management Connections for the QFX Series | 57

RJ-45 Management Port Connector Pinout Information | 58

Console Port Connector Pinouts for the QFX Series | 59

QSFP Port Connector Pinout Information | 60

SFP, SFP+, and SFP28 Port Connector Pinout Information | 64

| USB Port Specifications for the QFX Series | 65

## **Initial Installation and Configuration**

### **Unpack and Mount the QFX5241-32OD Switch | 68**

| Unpack QFX5241-32OD Switch | 68

Register Products—Mandatory to Validate SLAs | 70

Mount the QFX5241-32OD Switch on a Square Hole Rack by Using the QFX5241-1U-4PRMK Rack Mount Kit | 71

Mount Your QFX5241-32OD Switch on a Threaded-Hole Rack by Using the QFX5241-1U-4PRMK Rack Mount Kit | 75

## **Connect the QFX5241-32OD Switch to Power | 81**

Ground the QFX5241-32OD Switch | 81

Connect AC Power to QFX5241-32OD Switch | 83

## **Connect the QFX5241 Switch to External Devices | 85**

Connect a Device to a Network for Out-of-Band Management | 85

Connect a Device to a Management Console Using an RJ-45 Connector | 86

## **Perform Initial Software Configuration for QFX5241-32OD Switch | 88**

# 5

## **Maintain Components**

### **Maintain the QFX5241-32OD Cooling System | 92**

Remove a Fan Module from QFX5241-32OD Switch | 92

Install a Fan Module in QFX5241-32OD Switch | 94

### **Maintain the QFX5241-32OD Power System | 95**

Remove a Power Supply Unit from QFX5241-32OD Switch | 95

Install a Power Supply Unit in QFX5241-32OD Switch | 97

### **Maintain the Solid-State Drive in a QFX5241-32OD Switch | 98**

Remove the Solid-State Drive from a QFX5241-32OD Switch | 99

Install the Solid-State Drive in a QFX5241-32OD Switch | 100

### **Maintain Transceivers and Fiber Optic Cables on a QFX5241-32OD Switch | 102**

Remove a Transceiver | 102

Install a Transceiver | 105

Disconnect a Fiber-Optic Cable | 107

Connect a Fiber-Optic Cable | 108

| [How to Handle Fiber-Optic Cables](#) | 110

[Power Off a QFX5241-32OD Switch](#) | 111

## 6

### Troubleshoot Hardware

[Troubleshoot the QFX5241-32OD Switch](#) | 114

| [QFX5241-32OD Troubleshooting Resources Overview](#) | 114

| [QFX5241-32OD Alarm Messages Overview](#) | 115

| [Chassis Alarm Messages](#) | 117

## 7

### Contacting Customer Support and Returning the Chassis or Components

[Return QFX5241-32OD Chassis or Components](#) | 121

| [Return a QFX541-32OD Switch or Component for Repair or Replacement](#) | 121

| [Contact Customer Support to Obtain a Return Material Authorization](#) | 122

| [Locate the Serial Number on QFX5241-32OD Devices or Components](#) | 123

| | [List the Chassis and Component Details with the CLI](#) | 123

| | [Locate the Chassis Serial Number ID Label on QFX5241-32OD Switch](#) | 125

| | [Locate the Serial Number ID Labels on FRUs in a QFX5241-32OD Switch](#) | 125

| [Remove the Solid-State Drives for RMA on a QFX5241-32OD Switch](#) | 126

| [How to Return a Hardware Component to Juniper Networks, Inc.](#) | 129

| [Guidelines for Packing Hardware Components for Shipment](#) | 129

| [Pack QFX5241-32OD Switch or Component for Shipping](#) | 130

| | [Pack a QFX5241-32OD Switch for Shipping](#) | 130

| | [Pack QFX5241-32OD Components for Shipping](#) | 131

## 8

### Safety and Compliance Information

[Safety Information](#) | 133

[Compliance Statements for EMC Requirements](#) | 133

[Compliance Standards for QFX5241-32OD Switches](#) | 135

# About this Guide

Use this guide to plan, install, perform initial software configuration, perform routine maintenance, and troubleshoot the Juniper Networks® QFX5241-32OD switch.

After completing the installation and basic configuration procedures covered in this guide, see the Junos OS Evolved documentation for further software configuration.

# 1

CHAPTER

## Fast Track: Initial Installation

---

### IN THIS CHAPTER

- [Fast Track to Rack Installation and Powering Connection | 2](#)
  - [Onboard, Configure, and Monitor QFX5241-32OD Switch | 11](#)
-

# Fast Track to Rack Installation and Powering Connection

## SUMMARY

This procedure walks you through the basic steps for installing your QFX5241-32OD switch on a square-hole rack and connecting the switch to power. For more complex installation needs, see ["Unpack and Mount the QFX5241-32OD Switch"](#) on page 68.

## IN THIS SECTION

- [Install the QFX5241-32OD Switch on a Square Hole Rack by Using the QFX5241-1U-4PRMK Rack Mount Kit](#) | 2
- [Connect the QFX5241-32OD Switch to Power](#) | 7

You can install the AC variant of the Juniper Networks® QFX5241-32OD Switch on a four-post rack using the toolless QFX5241-1U-4PRMK rack mount kit (RMK). This RMK is the default rack mount kit available with the QFX5241-32OD switch.

Let's walk you through the steps to install the QFX5241-32OD switch using the QFX5241-1U-4PRMK for the square hole rack. For information on the threaded-hole rack installation steps, see ["Mount Your QFX5241-32OD Switch on a Threaded-Hole Rack by Using the QFX5241-1U-4PRMK Rack Mount Kit"](#) on page 75.

**Before you install the switch, review:**

- ["QFX5241-32OD Site Guidelines and Requirements"](#) on page 44.
- ["Safety Information"](#) on page 133.
- ["Unpack and Mount the QFX5241-32OD Switch"](#) on page 68.

## Install the QFX5241-32OD Switch on a Square Hole Rack by Using the QFX5241-1U-4PRMK Rack Mount Kit

## SUMMARY

Here, we'll walk you through the steps to install the QFX5241-32OD switch in a four-post square-hole rack using the default RMK.

---

1. Unpack the switch and place it on a flat stable surface.
2. Verify the parts received.
3. Ensure that you have the following tools and parts available:
  - An electrostatic discharge (ESD) grounding strap—not provided
  - QFX5241-1U-4PRMK rack mount kit (RMK)—provided

To mount the device on four posts in a rack by using the QFX5241-1U-4PRMK rack mount kit (RMK):

1. Review the [General Safety Guidelines and Warnings](#).
2. Wrap and fasten the ESD grounding strap to your bare wrist, and connect the other end of the strap to the ESD point on the device.
3. To attach the side-mounting brackets to the chassis, align the keyholes on the mounting brackets over the shoulder screws on the chassis. Slide the mounting brackets toward the rear of the chassis.

**Figure 1: Attach the Side-Mounting Brackets to the Chassis**

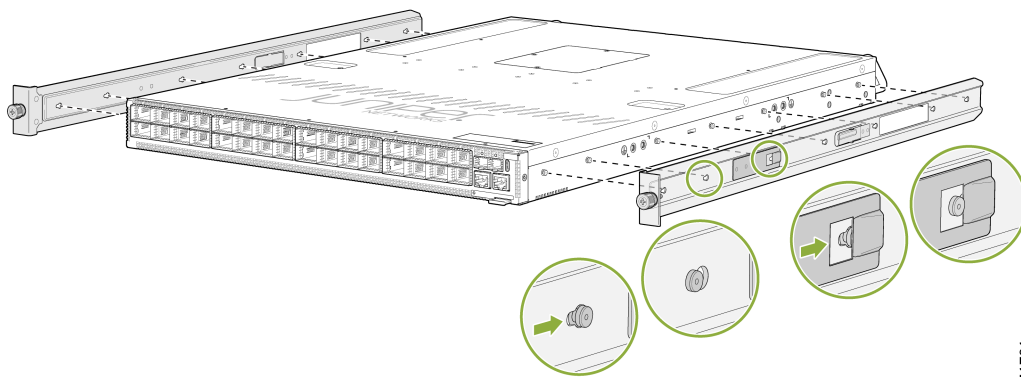

4. You can also flush mount the chassis on the rear side.

Figure 2: Flush Mount the Chassis from Rear Side

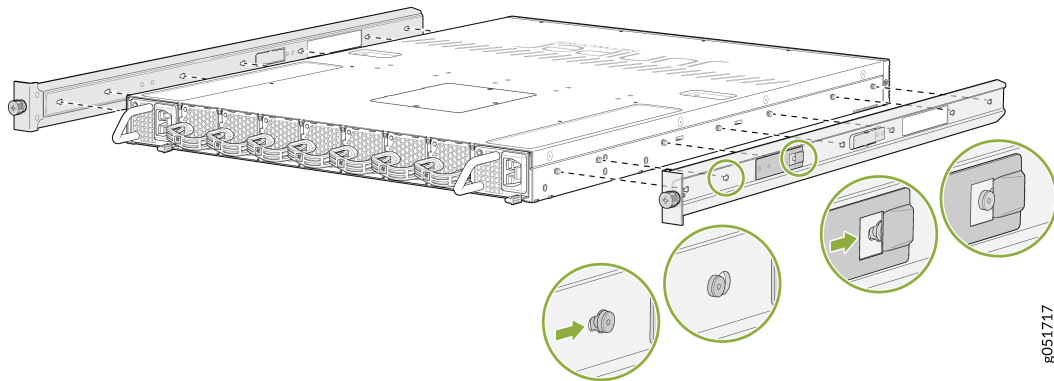

**NOTE:** Flip the rails when you flush mount the chassis on the rear side.

5. Assemble the mounting rails by sliding the rear floating rails into the front rails.

Figure 3: Assemble the Front and Rear Mounting Rails

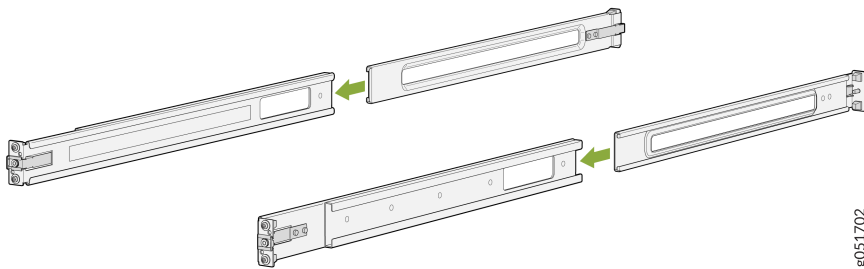

6. Attach the mounting rails to the rack.
  - a. Standing in front of the rack, align the guide blocks of the rear-mounting rails with the rear-post holes. Pull the rear-mounting rails toward the front of the rack to lock the rails in place. You will hear a click sound when the latch locks into the corresponding rack holes.

**Figure 4: Install the Rear Floating Rails**

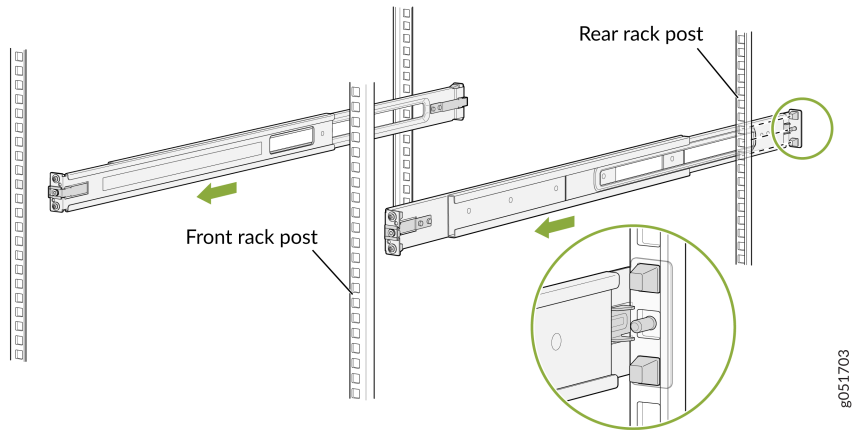

- b. Move the latch lock on the front-mounting rail to open position, slide the front-mounting rail, and insert the guide blocks into the front rack posts.

**Figure 5: Attach the Front Mounting Rails to the Rack Posts**

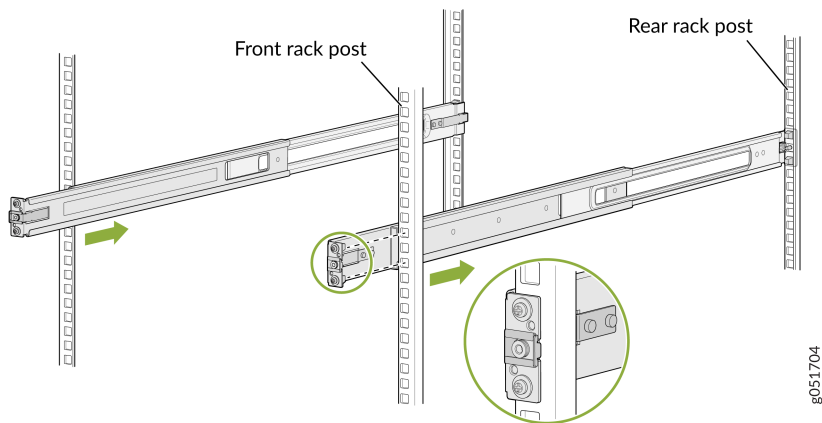

- c. Ensure that the front and rear latches on the mounting rails are locked in place. The mounting rails are now fully installed.

**Figure 6: Mounting Rails Fully Installed**

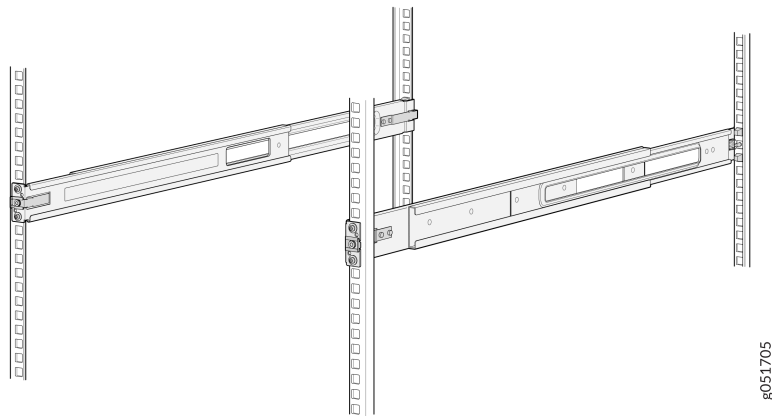

**i** **NOTE:** Install the grounding lug after RMK installation.

7. Lift the device and position it in the rack, aligning the side-mounting brackets with the mounting rails. Slide the device into the channels of the mounting rails.

**Figure 7: Attach the QFX5241-32OD Chassis to the Rack**

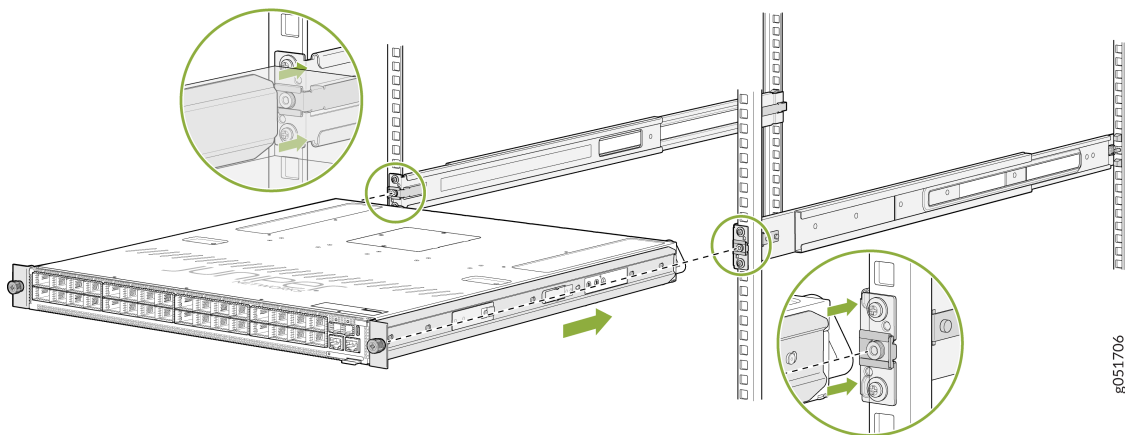

8. Tighten the two thumbscrews to secure the switch.

**Figure 8: Tighten the Thumbscrews**

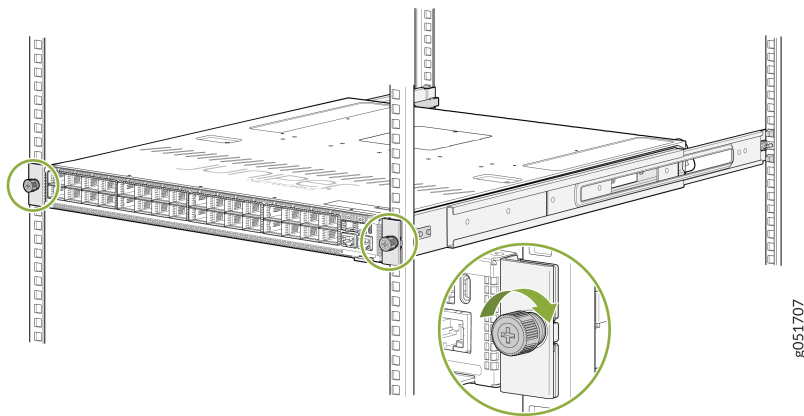

## Connect the QFX5241-32OD Switch to Power

### IN THIS SECTION

- Ground the QFX5241-32OD Switch | 7
- Connect AC Power to QFX5241-32OD Switch | 9

### Ground the QFX5241-32OD Switch

You must connect the QFX5241-32OD switch to earth ground before you connect it to power. Grounding helps your switch meet safety and EMI requirements and ensures that the switch functions properly.

You must install the QFX5241-32OD switch in a restricted-access location and ensure that the chassis is always properly grounded. The QFX5241-32OD switch comes with a two-hole protective grounding terminal provided on the side of the chassis. See [Figure 9 on page 9](#). Under all circumstances, use this grounding connection to ground the chassis. For AC-powered systems, you must also use the grounding wire in the AC power cord along with the two-hole grounding lug connection. The system is tested to ensure that it meets or exceeds all applicable EMC regulatory requirements for the two-hole protective grounding terminal.



**CAUTION:** Ensure that a licensed electrician has attached an appropriate grounding lug to the grounding cable that you supply. Using a grounding cable with an incorrectly attached lug can damage the device.



**NOTE:** Install your switch in the rack before attaching the grounding lug to the switch.

Ensure that you have the following parts and tools available:

- A grounding cable (not provided)—6 AWG, minimum 90 °C wire, or as permitted by the local code.
- A grounding lug (not provided)—Panduit LCD6-14A-L or equivalent grounding lug. The grounding lug attaches to the device chassis through the left-front mounting bracket, providing a protective earthing terminal for the device.
- Two M6 screws, 6 mm length with star washers (not provided)
- Phillips (+) screwdriver, number 2
- ESD grounding strap (not provided)

To ground the QFX5241-32OD switch:

1. Wrap and fasten one end of the electrostatic discharge (ESD) grounding strap around your bare wrist, and connect the other end to a site ESD point or to the ESD point on your device.
2. Remove the two M6 screws with star washers from the earthing terminal on the sides of the chassis.
3. Place the Panduit LCD6-14A-L or equivalent grounding lug attached to the grounding cable over the protective earthing terminal. Attach the lug through the left-mounting bracket to the chassis.
4. Secure the grounding lug to the protective earthing terminal using the two M6 screws with star washers.

**Figure 9: Connect a Grounding Cable to the QFX5241-32OD AC Switch**

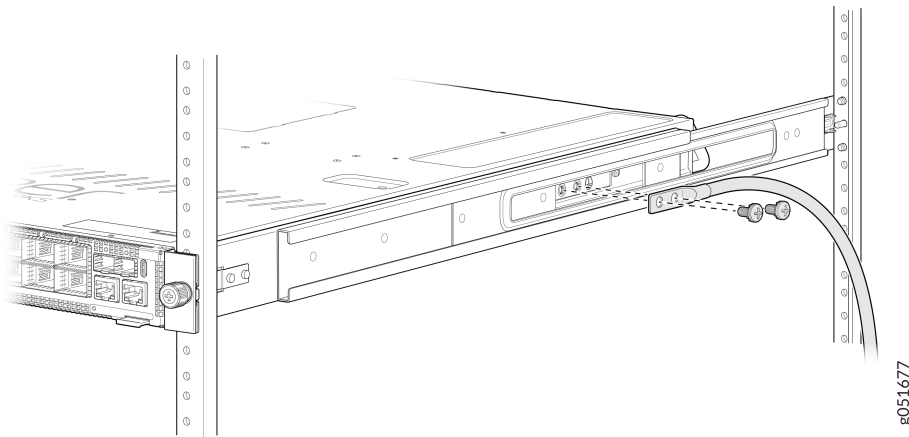

**i** **NOTE:** Install the grounding lug after RMK installation.

5. Connect the remaining end of the grounding cable to a proper earth ground, such as the rack in which the switch is mounted.
6. Dress the grounding cable to ensure safety.

**i** **NOTE:**

- The grounding cable must not touch other device components or obstruct access to the device.
- Arrange the cable such that it does not drape in areas where people could trip over it.

To gain additional grounding for the chassis of your QFX5241-32OD switch, connect the PSU in the switch into a grounded power outlet. Use a power cord appropriate for your geographical location.

### Connect AC Power to QFX5241-32OD Switch

Ensure that you have a power cord appropriate for your geographical location available to connect AC power to the switch.

Before you begin connecting AC power to the switch:

- Ensure that you have taken the necessary precautions to prevent electrostatic discharge (ESD) damage.

- Ensure that you have connected the switch chassis to earth ground. See ["Ground the QFX5241-32OD Switch" on page 7](#)



**CAUTION:** Before you connect power to the switch, a licensed electrician must attach a cable lug to the grounding cables that you supply. A cable with an incorrectly attached lug can damage the switch (for example, by causing a short circuit).

To meet safety and electromagnetic interference (EMI) requirements and to ensure proper operation, you must connect the chassis to earth ground before you connect it to power. For installations that require a separate grounding conductor to the chassis, use the protective earthing terminal on the switch chassis to connect to the earth ground. For instructions on connecting earth ground, see ["Ground the QFX5241-32OD Switch" on page 7](#). The switch gains additional grounding when you plug the PSU in the switch into a grounded power outlet by using the AC power cord appropriate for your geographical location.

- Install the power supply units (PSUs) in the chassis. For instructions on installing the PSU in the QFX5241-32OD switch, see ["Install a Power Supply Unit in QFX5241-32OD Switch" on page 97](#).

The QFX5241-32OD switch ships from the factory with two preinstalled AC PSUs. The AC PSUs offer 1+1 redundancy. The PSUs are hot-removable and hot-insertable field-replaceable units (FRUs). You can replace a PSU in the slots adjacent to the fan modules without powering off the switch or disrupting its operation.



**NOTE:** Each PSU must be connected to a dedicated power source outlet.

To connect AC power to the QFX5241-32OD switch:

1. Wrap and fasten one end of the ESD grounding strap around your bare wrist, and connect the other end to a site ESD point.
2. Ensure that the PSUs are fully inserted in the chassis and the latches are secure.
3. Locate the power cords shipped with the switch; the cords have plugs appropriate for your geographical location. See ["AC Power Cord Specifications" on page 34](#).

For each PSU:

- a. Connect the AC power cord. Insert the power cord coupler firmly into the AC inlet on the PSU faceplate.

Figure 10: Connect the AC Power Cord

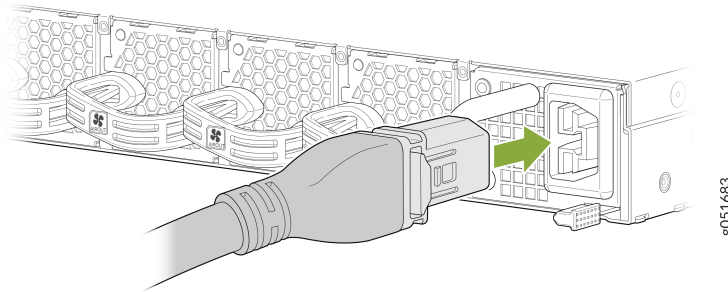

- b. Connect a dedicated customer-site two-pole circuit breaker for each PSU. We recommend that you use a dedicated customer-site circuit breaker rated for 20 A (250 V), or as required by local code.
4. If the AC power source outlet has a power switch, set it to the off (O) position.



**NOTE:** The switch powers on as soon as you provide power to the PSU. The device does not have a power switch.

5. Insert the power cord plug into an AC power source outlet.
6. If the AC power source outlet has a power switch, set it to the on (I) position.
7. Verify that the status LEDs on each PSU are lit green.

If the status LED is lit amber, disconnect the power cords from the PSU and replace the PSU. See ["Maintain the QFX5241-32OD Power System" on page 95](#).

Remove the PSU from the switch only when you have a replacement PSU ready. Install the PSUs in the switch to ensure proper airflow.

## Onboard, Configure, and Monitor QFX5241-32OD Switch

### SUMMARY

This topic provides you with pointers to onboard, configure, and monitor QFX5241-32OD switch using Juniper Apstra or CLI (configure only).

You can use Juniper Apstra to onboard, configure, and monitor the QFX5241-32OD switch. See [Table 1 on page 12](#) for more information.

**Table 1: Onboard, Configure, and Monitor QFX5241-32OD Switch Using Juniper Apstra**

If You Want To	Then
Install and configure Juniper Apstra	See <a href="#">Juniper Apstra Quick Start Guide</a>
Use Juniper Apstra	See <a href="#">Juniper Apstra User Guide</a>
See all documentation available for Juniper Apstra	See <a href="#">Juniper Apstra Documentation</a>

You can configure the QFX5241-32OD switch using the CLI. See [Table 2 on page 12](#) for more information.

**Table 2: Configure QFX5241-32OD Switch Using the CLI**

If You Want To	Then
Customize the basic configuration	See <a href="#">"Perform Initial Software Configuration for QFX5241-32OD Switch" on page 88</a>
Configure supported software features on the QFX5241-32OD switch	See <a href="#">Software Documentation</a>
Stay up to date about new and changed features, and known and resolved issues	See <a href="#">Junos OS Evolved Release Notes</a>

# 2

CHAPTER

## Overview

---

### IN THIS CHAPTER

- [QFX5241-32OD System Overview | 14](#)
  - [QFX5241-32OD Port Panel | 21](#)
  - [QFX5241-32OD Switch Management Panel | 24](#)
  - [QFX5241-32OD Power System | 32](#)
  - [QFX5241-32OD Cooling System | 37](#)
-

# QFX5241-32OD System Overview

## IN THIS SECTION

- [QFX5241-32OD Switch Description | 14](#)
- [QFX5241-32OD Hardware Component Overview | 17](#)
- [System Software | 18](#)
- [QFX5241-32OD Component Redundancy | 18](#)
- [QFX5241-32OD FRUs | 20](#)
- [QFX5241-32OD Chassis Physical Specifications | 20](#)

## QFX5241-32OD Switch Description

### IN THIS SECTION

- [Benefits | 16](#)

The Juniper Networks® QFX5241 Switch is a device with high port density. You can use this switch as end-of-row, leaf or spine devices in an IP fabric architecture. It is an optimal choice as shallow buffer platforms for the spine role in the data center fabric. The 32-port QFX5241 switch is available as the model QFX5241-32OD.

The QFX5241-32OD switch has AC power supply units (PSUs) and an airflow out (AFO) cooling system.

**Table 3: 32-Port QFX5241 Switch: Key Specifications**

Characteristics	QFX5241-32OD	Notes
Data transmission capability	800 Gbps	The switch offers up to 800 Gbps of data transmission speed through the 800-Gigabit Ethernet (GbE) ports.

Table 3: 32-Port QFX5241 Switch: Key Specifications *(Continued)*

Characteristics	QFX5241-32OD	Notes
Rack units (U)	1 U	The switch has chassis that occupy one rack units (1 U).
Form factor	<ul style="list-style-type: none"> <li>• Octal small form-factor pluggable (OSFP)—32 OSFP ports with speeds of up to 800 Gbps.</li> <li>• 2 SFP28 ports with speeds of 10 Gbps.</li> </ul>	
Ports	<ul style="list-style-type: none"> <li>• 32 OSFP ports (800 Gbps)</li> <li>• 2 SFP28 ports (10 Gbps)</li> <li>• 1 Type-C USB 3.0 port</li> <li>• 1 RJ-45 console port</li> <li>• 1 management port</li> </ul>	
Throughput	25.6 terabits per second (Tbps)	
Processor	Intel 4-core 2.2-GHz Ice Lake D processor with 32 GB DRAM	The processor drives the control plane of the switch.
Operating system (OS)	Junos OS Evolved software	Two internal 480-GB Non-Volatile Memory Express (NVMe) solid-state drives (SSDs) store the Junos OS Evolved software image.

**Figure 11: Front View of the QFX5241-32OD Switch**

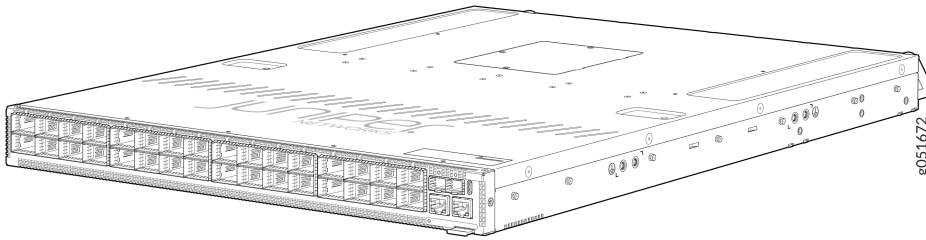

**Figure 12: Rear View of the QFX5241-32OD AC Switch**

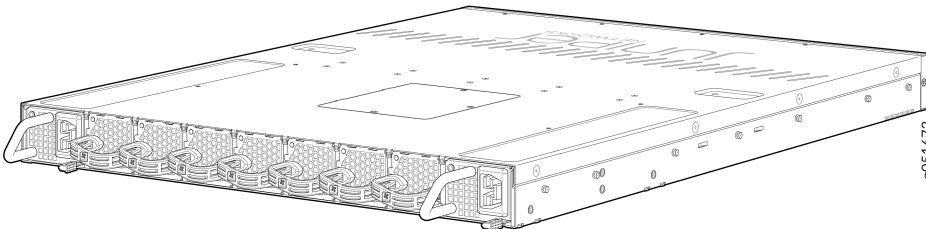

## Benefits

- High capacity (25.6 Tbps) and low latency support ensures efficient handling of large data exchanges required for AI/ML workloads.
- A 1-U switch with 32 ports of 800 Gbps reduces costs by minimizing space and total power utilization.
- Customers save power with 800G optics over 2x400G optics. The QFX5241-32OD supports linear pluggable optics (LPO), which uses half the power of traditional optics.
- Fast link failover enhances network reliability by rapidly detecting and responding to link failures, which maintains continuous operation.
- Drop congestion notification improves congestion management by allowing packet trimming and metadata transmission, which minimizes data loss and latency.
- EVPN-VXLAN support enables flexible network segmentation and multitenant deployments, optimizing data center design and reducing deployment complexity.
- Secure boot capabilities increase security by protecting the integrity of the switch from unauthorized firmware modifications.

- An automated rail-optimized design handles complex flows through Apstra.

## QFX5241-32OD Hardware Component Overview

The QFX5241-32OD switches have the following variants:

- QFX5241-32OD-AO—32-port switches with 800-Gbps data transmission capability, octal small form-factor pluggable (OSFP) form factor, AC PSU, airflow out (AFO) cooling design, and installation using the QFX5241-1U-4PRMK rack mount kit.

Table 4 on page 17 provides an overview of the QFX5241-32OD variants. The table also provides details about the power supply units (PSUs), field-replaceable units (FRUs), and airflow out (AFO) cooling system for the switch.

**Table 4: Hardware Component Overview of QFX5241-32OD**

Variant	Description	Airflow	Power System	Spare Chassis
QFX5241-32OD-AO	<ul style="list-style-type: none"> <li>• 32 OSFP ports (ports 0–31) with port speed of up to 800 Gbps</li> <li>• 2 SFP28 ports (ports 32 and 33) with port speed of up to 10 Gbps</li> <li>• 1 USB 3.0 port (<b>SS</b>)</li> <li>• 1 RJ-45 console port (<b>CONSOLE</b>)</li> <li>• 1 management (<b>MGMT</b>) port</li> </ul> <p>Install using the rack mount kit QFX5241-1U-4PRMK.</p>	Seven hot-insertable and hot-removable fan modules with front-to-back or AFO airflow, indicated by the label <b>AIR OUT</b> .	Two 12-V, 2400-W AC PSUs with AFO cooling system. The PSUs are hot-insertable and hot-removable FRUs that provide 1 + 1 redundancy and load sharing.	QFX5241-32OD-CHAS



**NOTE:** Spare chassis does not include RMK, PSUs, and fans for the QFX5241-32OD switch.

The QFX5241-32OD switches have the following spare chassis:

**Table 5: QFX5241-32OD Spare Chassis Details**

Chassis	Description
QFX5241-32OD-CHAS	Spare chassis without PSUs and fans for the QFX5241-32OD model

## System Software

The QFX5241-32OD switch uses the Junos OS Evolved operating system. Junos OS Evolved provides several capabilities that include Layer 2 and Layer 3 switching, routing, and security services. The Junos OS Evolved software is installed on the solid-state drives (SSD) in the switch.

You can manage the switch using the Junos OS Evolved CLI, accessible through the console and out-of-band management ports on the device.

## QFX5241-32OD Component Redundancy

The following hardware components provide redundancy on the QFX5241-32OD switch:

- QFX5241-32OD AC PSU—QFX5241-1U-PWR-AO, the AC PSU for QFX5241-32OD, is a hot-removable and hot-insertable FRU. The PSUs offer 1+1 redundancy for the AC input voltage range of 200 V through 240 V (up to 2400 W). However, for the AC input voltage range of 100 V through 127 V (up to 1000 W), there is no redundancy support. When installing or replacing the PSU, you don't need to shut down the device or interfere with the switching process.



**NOTE:** QFX5241-32OD AC switch operates only in nonredundant mode when the AC input voltage range is 100–127 V. Any PSU or input power failure causes a system

failure in nonredundant mode. Maintain a minimum system input above 200 V for full-load operation in redundant mode.

**Table 6: QFX5241-32OD AC PSU Specifications**

PSU	Item	Specification
QFX5241-1U-PWR-AO (for AC PSU, AFO, 1-U variant)	Maximum output power	2400 W (for input voltage of 200 V through 240 V)  1000 W (for input voltage of 100 V through 127 V)
	Maximum input power	2600 W (for input voltage of 220 V)  1100 W (for input voltage of 110 V)
	AC input current rating	15 A (for input voltage of 200 V through 240 V; 50/60 Hz)  12 A (for input voltage of 100 V through 127 V)
	AC input voltage	High input voltage range: 200 V through 240 V.  Low input voltage range: 100 V through 127 V.
	Output voltage (DC)	12 V (for both high and low voltage ranges)
	AC input line frequency	50 Hz through 60 Hz

- QFX5241-32OD cooling system—QFX5241-1U-FAN-O, for QFX5241-32OD, is a hot-removable and hot-insertable FRU. The cooling system consists of seven front-to-back (airflow out or AFO) fan modules with each fan module containing two rotors. The cooling system offers  $N+1$  redundancy for the fan modules. The fan modules are hot-insertable and hot-removable field-replaceable units (FRUs).

Table 7: Cooling System Specifications

Fan Module	Description	Airflow	Fan Replacement Duration
QFX5241-1U-FAN-O	Seven 12 V fan modules. The fan modules of 40 mm x 56 mm dimension are hot-insertable and hot-removable FRUs.	Airflow out (AFO), also known as front-to-back or port-to-FRU airflow	2 minutes for ambient temperature of 104 °F (40 °C)

## QFX5241-32OD FRUs

Field-replaceable units (FRUs) are switch components that you can replace at your site. The QFX5241-32OD are:

- Hot-insertable and hot-removable—You can remove and replace these components without powering off the switch or disrupting the switching function.
- Hot-pluggable—You can remove and replace these components without powering off the switch, but the switching function is interrupted until you replace the component.

The PSUs and fan modules in the QFX5241-32OD switch are hot-insertable and hot-removable FRUs. That is, you can replace them without turning the switch off or interfering with its functionality. The FRUs such as fan modules and PSUs are installed on the FRU panel at the rear of the QFX5241-32OD chassis.

Table 8: QFX5241-32OD Field-Replaceable Units

## QFX5241-32OD Chassis Physical Specifications

The QFX5241-32OD chassis are rigid sheet-metal structures that house the hardware components.

Table 9: Physical Specifications of QFX5241-32OD Chassis

Variant	Height	Width	Depth	Weight
QFX5241-32OD-AO	1.72 in. (4.37 cm)	17.26 in. (43.84 cm)	23.19 in. (58.9 cm)	31.65 lb (14.36 kg) fully loaded without optics

## QFX5241-32OD Port Panel

### IN THIS SECTION

- [QFX5241-32OD Network Port LEDs](#) | 22

The port panel of the QFX5241-32OD switch has 32 high-speed network ports. These ports support data transmission speeds of up to 800 Gbps. The 32 ports (numbered 0 to 31) in the QFX5241-32OD support octal small form-factor pluggable (OSFP) transceivers. For information about the optical transceivers and cables that support 800 Gbps transmission in QFX5241-32OD, see [Hardware Compatibility Tool \(HCT\)](#).

Apart from the 32 network ports in the ports panel, the QFX5241-32OD switch offers the following ports in the management panel:

- Two SFP28 ports
- One USB 3.0 (**SS**) port
- One RJ-45 console (**CONSOLE**) port
- One management (**MGMT**) port

-  **NOTE:** For information about the ports in management panel, see "[QFX5241-32OD Switch Management Panel](#)" on page 24.

Figure 13: QFX5241-32OD Ports Panel



1– Network ports panel (with 32 800GbE OSFP ports)	5– Pull tab
2– SFP28 ports	6– Status LEDs (ID, SYS, ALM) and reset (RST) button
3– USB 3.0 port (SS)	7– RJ-45 Management port (MGMT)
4– RJ-45 console port (CONSOLE)	

## QFX5241-32OD Network Port LEDs

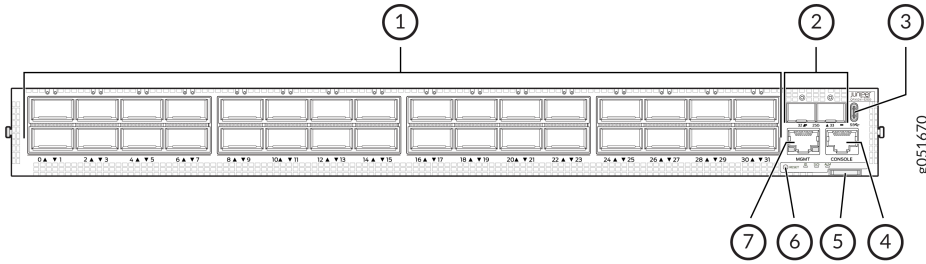
The high-speed OSFP network ports on QFX5241-32OD use a single RGB LED to indicate link status, activity on the link, or a fault condition. With one LED per OSFP network port, there are 32 LEDs for the OSFP network ports.

Figure 14: Network Port LEDs on a QFX5241-32OD Switch

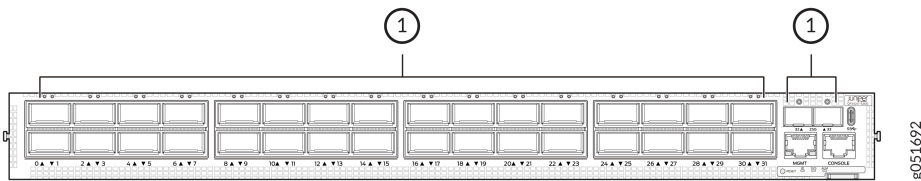

1– Network port LEDs
----------------------

Table 10 on page 23 explains the behavior of the nonchannelized network ports LEDs of the QFX5241-32OD switch.

Table 10: QFX5241-32OD Network Port LEDs

Color	State	Description
Unlit	Off	By default, the LED is unlit, so it is in the Off state. The LED can be unlit even when power is present and a transceiver is present in the port.
		The link is down.
		Transceiver is not installed.
Green	On steadily	A 400-Gbps or 800-Gbps link is established, and there is link activity.
Yellow	On steadily	The link is down or the port experiences a fault other than loss of signal or transceiver hardware failure.
		The link is down because of a remote error or because the port was disabled through the CLI.
Red	On steadily	The link is down because the port or transceiver has a hardware failure.

# QFX5241-32OD Switch Management Panel

## IN THIS SECTION

- QFX5241-32OD Management Panel | 24
- QFX5241-32OD Management Panel LEDs | 25

## QFX5241-32OD Management Panel

The management panel is located in the front panel of a QFX5241-32OD switch. You can find the management panel to the right of the port panel. Apart from the 32 network ports in the ports panel that are numbered **0** to **31**, the QFX5241-32OD switch offers the following ports in the management panel:

- Two SFP28 Ports—Supports data transmission speeds of up to 10 Gbps using SFP28 transceivers. The SFP28 ports are numbered 32 and 33.
- One USB 3.0 (**SS**) port—Primarily used for storage and file transfers. For example, use this port to connect a USB drive to perform upgrades, export configuration files, or save log files.
- One RJ-45 console (**CONSOLE**) port—Provides direct serial communication with the switch to support tasks such as initial configuration, troubleshooting, and recovery.
- One RJ-45 management (**MGMT**) port—Supports out-of-band management of the switch. The typical use cases include secure management, remote management, monitoring, and logging.

Figure 15: QFX5241-32OD Management Panel

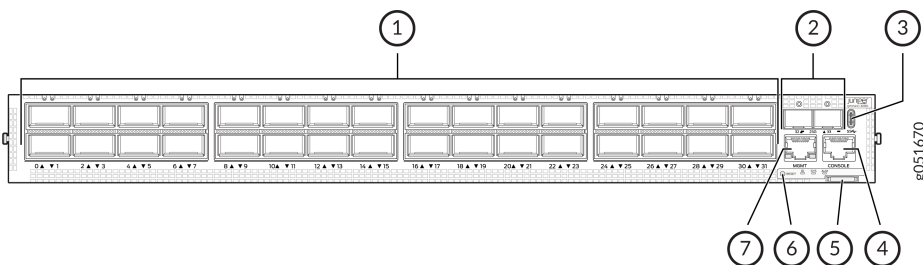

1– Network ports panel (with 32 800GbE OSFP ports)	5– Pull tab
2– SFP28 ports	6– Status LEDs ( <b>ID</b> , <b>SYS</b> , <b>ALM</b> ) and reset ( <b>RST</b> ) button
3– USB 3.0 port ( <b>SS</b> )	7– RJ-45 Management port ( <b>MGMT</b> )
4– RJ-45 console port ( <b>CONSOLE</b> )	

## QFX5241-32OD Management Panel LEDs

### IN THIS SECTION

- [QFX5241-32OD Chassis Status LEDs | 25](#)
- [Management Port LEDs | 30](#)

The management panel in the QFX5241-32OD switch has the following LEDs:

- Chassis Status LEDs
- Management port LEDs
- SFP28 port LEDs

The following sections explain how to interpret these LEDs.

### QFX5241-32OD Chassis Status LEDs

The QFX5241-32OD switch has three LED types that indicate system status. You can find these LEDs to the right of the network ports.

Figure 16: QFX5241-32OD Chassis Status LEDs

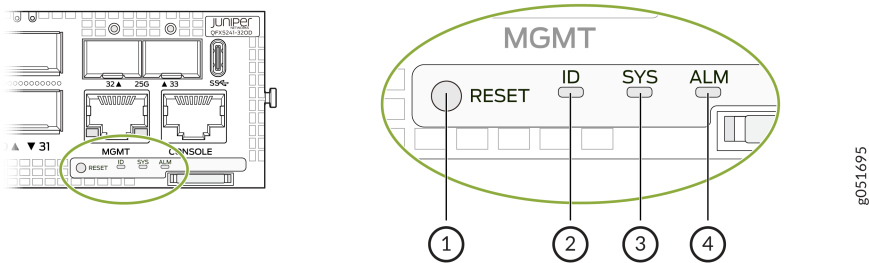

1– **RST**—Reset button. You can find the reset button beneath the **ID** LED. The reset button is *not* a status LED, although it is located in this panel.

**NOTE:** When you use the reset button, the device reboots. However, the existing configuration of the switch does not change. That is, the device does not return to the factory-default configuration.

3– **SYS**—System status

2– <b>ID</b> —Serves as a locator or identification indicator for the switch	4– <b>ALM</b> —Chassis alarm or fault
--	---------------------------------------

You can view the colors of the three LEDs remotely through the CLI by issuing the operational mode command `show chassis led`:

```

user@host> show chassis led
-----LEDs status:
  Alarm LED : Off
  Beacon LED: Off
  System LED: Green

Interface          STATUS LED   LINK/ACTIVITY LED
-----
et-0/0/0           N/A         Green
et-0/0/1           N/A         Green
et-0/0/2           N/A         Green
    
```

et-0/0/3	N/A	Green
et-0/0/4	N/A	Green
et-0/0/5	N/A	Green
et-0/0/6	N/A	Green
et-0/0/7	N/A	Green
et-0/0/8	N/A	Green
et-0/0/9	N/A	Green
et-0/0/10	N/A	Green
et-0/0/11	N/A	Green
et-0/0/12	N/A	Green
et-0/0/13	N/A	Green
et-0/0/14	N/A	Green
et-0/0/15	N/A	Green
et-0/0/16	N/A	Green
et-0/0/17	N/A	Green
et-0/0/18	N/A	Green
et-0/0/19	N/A	Green
et-0/0/20	N/A	Green
et-0/0/21	N/A	Green
et-0/0/22	N/A	Green
et-0/0/23	N/A	Green
et-0/0/24	N/A	Green
et-0/0/25	N/A	Green
et-0/0/26	N/A	Green
et-0/0/27	N/A	Green
et-0/0/28	N/A	Green
et-0/0/29	N/A	Green
et-0/0/30	N/A	Green
et-0/0/31	N/A	Green
et-0/0/32	N/A	Green
et-0/0/33	N/A	Green

user@host>

Table 11: Chassis Status LEDs on QFX5241-32OD Switch

Name	Color	State	Description
ALM (Alarm)	Unlit	Off	<p>The device is powered off or halted. There are no alarms for the QFX5241-32OD switch in this state.</p> <p><b>NOTE:</b> The ALM LED glows green during BIOS booting.</p>
	Red	On steadily	<p>A major hardware fault has occurred, such as fan or fan tray failure. The device has halted.</p> <p>Use the CLI commands <code>show chassis alarms</code>, <code>show system alarms</code>, and <code>show system errors active detail</code> to gather information about the error that triggered the alarm. This information helps to decide the recovery steps to perform.</p> <p>To troubleshoot, perform the following:</p> <ol style="list-style-type: none"> <li>1. Power off the device by setting the AC power source outlet to the off (O) position or by unplugging the AC power cords.</li> <li>2. Correct any voltage or site temperature issues, and allow the switch to cool down.</li> <li>3. Power on the device.</li> <li>4. Monitor the PSU LEDs and fan module LEDs to determine where the error is occurring.</li> </ol>
	Red	Blinking	<p>A major hardware fault has occurred, along with another minor hardware fault.</p>

Table 11: Chassis Status LEDs on QFX5241-32OD Switch (Continued)

Name	Color	State	Description
	Yellow	On steadily	<p>A minor system level alarm has occurred, such as a software error or a missing rescue configuration.</p> <p>Use the CLI commands <code>show chassis alarms</code>, <code>show system alarms</code>, and <code>show system errors active detail</code> to gather information about the error that triggered the alarm. This information helps to decide the recovery steps to perform.</p> <p>To troubleshoot, perform the following:</p> <ol style="list-style-type: none"> <li>1. Power off the device by setting the AC power source outlet to the off (O) position or by unplugging the AC power cords.</li> <li>2. Power on the QFX5241-32OD switch.</li> <li>3. Monitor the status LEDs to ensure that Junos OS Evolved boots properly.</li> </ol>
SYS (System)	Unlit	Off	<p>The device is powered off or halted.</p> <p><b>NOTE:</b> The <b>SYS</b> LED glows green during BIOS booting.</p>
	Green	On steadily	System self-diagnostic test has completed successfully.
	Red	On steadily	System self-diagnostic test has detected a fault (fan, thermal or any interface fault).

**Table 11: Chassis Status LEDs on QFX5241-32OD Switch (Continued)**

Name	Color	State	Description
ID (Identification)	Unlit	Off	The beacon feature is not enabled on the device. Enable this feature by using the request chassis beacon fpc 0 on operational mode command.  <b>NOTE:</b> The ID LED glows green during BIOS booting.
	Blue	Blinking	The beacon feature is enabled on the device. Disable this feature by using the request chassis beacon fpc 0 off operational mode command.

**TIP:** To know the status of the beacon, use the show chassis beacon operational mode command:

```
user@host> show chassis beacon
OFF
```

**NOTE:** The system LED is a tricolor LED (red, green, blue). This means it can also display additional colors, such as amber or blue.

## Management Port LEDs

The RJ-45 management port on the QFX5241-32OD switch has two LEDs that indicate link status and link activity. The management port is labeled **MGMT**.

Figure 17: Management Port LEDs on QFX5241-32OD Switch

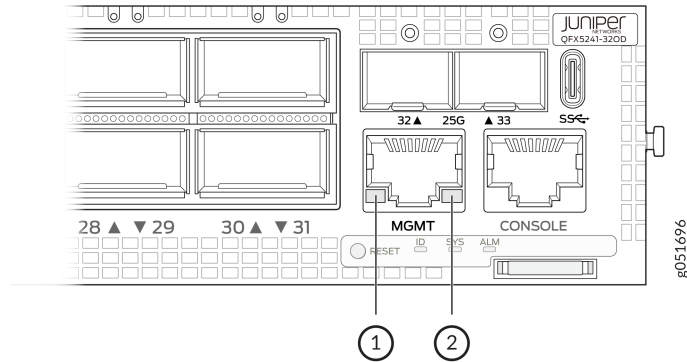

1– Status LED

2– Link activity LED

Table 12: Management Port LEDs on QFX5241-32OD Switch

LED	Color	State	Description
Blinking or flickering	A link is established, and there is link activity.		
Status	Unlit	Off	Either the port speed is 10 Mbps or the link is down.
	Green	On steadily	The port speed is either 1 Gbps or 100 Mbps.

The management panel also has two SFP28 ports with one LED each.

Table 13: SFP28 Port LEDs on QFX5241-32OD Switch

LED	Color	State	Description
Status	Unlit	Off	No link is established. There is a fault, or the link is down.
	Green	On steadily	A link is established and available.

# QFX5241-32OD Power System

## IN THIS SECTION

- [QFX5241-32OD AC Power Supply Unit Description | 33](#)
- [AC Power Cord Specifications | 34](#)
- [QFX5241-32OD AC Power Supply Unit LED | 35](#)

QFX5241-1U-PWR-AO—Two redundant AC power supply units (PSUs) power the AC variant of QFX5241-32OD switch (with 1 + 1 redundancy). For voltage inputs between 200 V and 240 V, each QFX5241-1U-PWR-AO PSU provides a maximum output of 2400 W. The AC PSU consumes a maximum input power of 2600 W from the power outlet to produce the maximum output of 2400 W. For voltage inputs between 100 V and 127 V, each QFX5241-1U-PWR-AO PSU provides a maximum output of 1000 W. The AC PSU consumes a maximum input power of 1100 W from the power outlet to produce the maximum output of 1000 W. The PSU modules support AFO cooling, also known as front-to-back or ports-to FRUs airflow. The PSUs are fully redundant and perform load sharing after you install and power on the second PSU. The AC PSUs are hot-removable and hot-insertable FRUs. That is, you can remove and replace the PSUs without powering off the switch or disrupting the functioning of the switch.



**NOTE:** QFX5241-32OD AC switch operates only in nonredundant mode when the AC input voltage range is 100–127 V. Any PSU or input power failure causes a system failure in nonredundant mode. Maintain a minimum system input above 200 V for full-load operation in redundant mode.

The PSUs of the QFX5241-32OD switch are located in the FRU panel at the rear of the chassis.

**Figure 18: QFX5241-32OD AC FRU Panel**

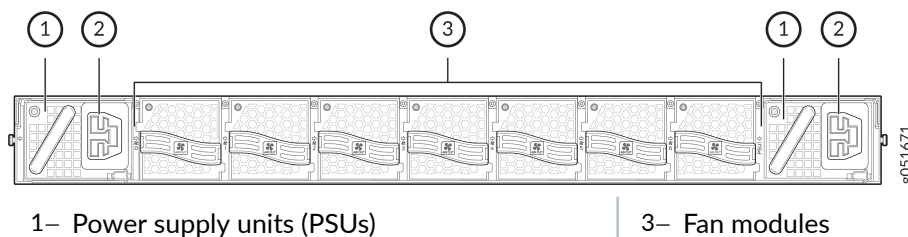

## QFX5241-32OD AC Power Supply Unit Description

Each 2400-W AC PSU has a single AC input that provides 12 V of output voltage. The maximum output power of the PSU is 2.4 kilowatt (kW) or 2400 W for the input voltage range of 200 V through 240 V. At maximum load, the AC input current rating is 15 A for an input voltage of 220 V.



**NOTE:** At the output power and input voltages provided, you can maintain the input current of the switch within the rated limits.

**Table 14: AC Power Specifications for QFX5241-32OD Switch**

Item	Specifications
AC input voltage	High input voltage range: 200 V through 240 V. Low input voltage range: 100 V through 127 V.
AC input current rating	15 A (for the input voltage of 200 V through 240 V) 12 A (for the low input voltage range)
AC input line frequency	50 Hz through 60 Hz (for both high and low voltage ranges)
Maximum input power	2600 W (for input voltage of 220 V) 1100 W (for input voltage of 110 V)
Output voltage (DC)	12 V (for both high and low voltage ranges)
Maximum output power	2400 W (for input voltage of 200 V through 240 V) 1000 W (for input voltage of 100 V through 127 V)

Figure 19: QFX5241-32OD AC Power Supply Unit

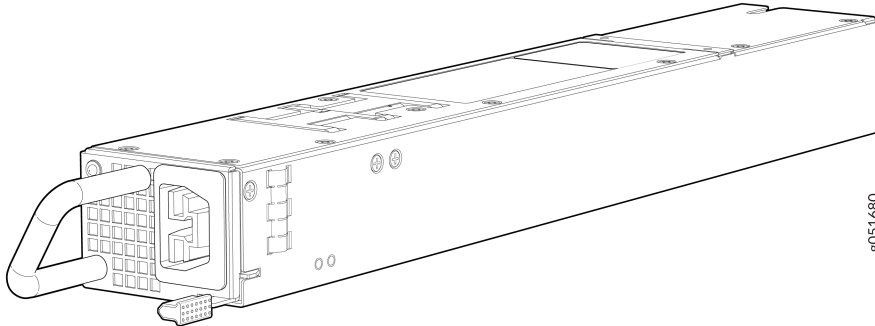
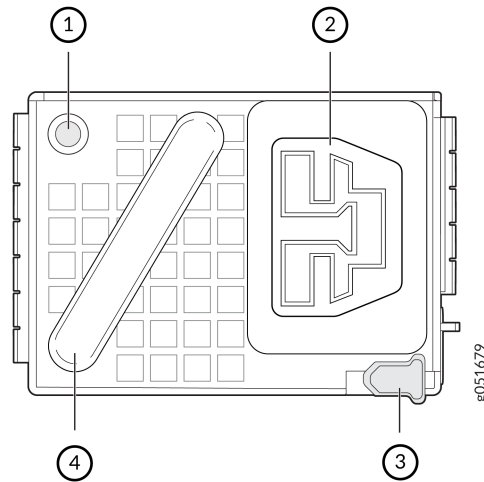

Figure 20: Front View of QFX5241-32OD AC Power Supply Unit



1– PSU LED

2– Power connector

3– Ejector latch

4– Handle

To replace a PSU, see "[Maintain the QFX5241-32OD Power System](#)" on page 95.

## AC Power Cord Specifications

We ship detachable AC power cords with the chassis. The AC power cord *CG\_CBL-SDG-C20-2M* ships by default along with the QFX5241-32OD AC switches.



**NOTE:** In North America, AC power cords must not exceed 14.75 feet (approximately 4.5 meters) in length, to comply with National Electrical Code (NEC) Sections 400-8 (NFPA 75, 5-2.2) and 210-52, and Canadian Electrical Code (CEC) Section 4-010(3). The cords that can be ordered for the QFX Series switches are in compliance.

Table 15 on page 35 lists AC power cord specifications provided for each country or region.

**Table 15: AC Power Cord Specifications**

Country/Region	Electrical Specifications	Standards	Juniper Model Number
All countries (except Japan and India)	250 V, 20 A (US), 16 A (rest of the world)	SAF-D-Grid 400 to IEC 60320 C20	CG_CBL-SDG-C20-2M
Japan	250 V, 16 A	SAF-D-Grid 400 to IEC 60320 C20	CG_CBL-SDG-C20-2M
India	250 V, 16 A	SAF-D-Grid 400 to IEC 60320 C20	CG_CBL-SDG-C20-2M

## QFX5241-32OD AC Power Supply Unit LED

Each QFX5241-32OD switch PSU has a single LED on the module faceplate to indicate the power status.

**Figure 21: QFX5241-32OD AC PSU LED Location**

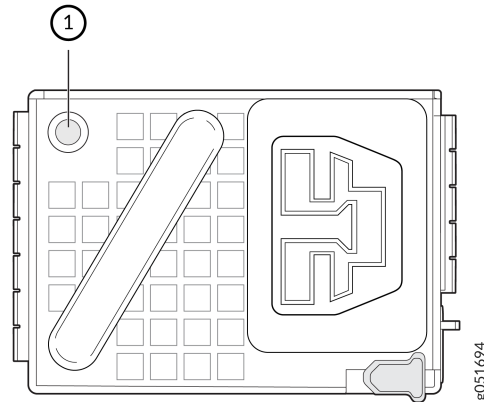

1– AC PSU LED

The AC PSU uses a red and green bicolor LED to indicate the operating state.

**Table 16: QFX5241-32OD AC PSU LED Color and State**

LED Color and State	Description
Off	All the PSUs in the switch are not receiving AC power.
Solid green	The PSU is on and functioning properly, producing 12 V output.
Blinking green (0.5 second on, 0.5 second off)	The PSU is in standby mode (PSU is receiving AC power, but only 5 V).
Blinking green (0.25 second on, 0.25 second off,)	The PSU is undergoing a firmware update.
Blinking on and off (0.5 second red, 0.5 second off, 0.5 second green, 0.5 second off )	The PSU is issuing a warning or alert about a fault condition.
Solid red	The PSU is indicating a critical power supply failure.
Blinking red (1 second red, 1 second off)	The specific PSU is not receiving AC power.

Table 16: QFX5241-32OD AC PSU LED Color and State *(Continued)*

LED Color and State	Description
	The PSU is indicating a fault with its fan module.

## QFX5241-32OD Cooling System

### IN THIS SECTION

- [QFX5241-32OD Cooling System Description | 37](#)

## QFX5241-32OD Cooling System Description

### IN THIS SECTION

- [Fan Modules | 38](#)
- [Airflow | 40](#)
- [Power Supply Cooling System | 41](#)

The components of the cooling system work together to keep the switch within the acceptable temperature range. The cooling system consists of the following components:

- ["Fan Modules" on page 38](#)
- ["Airflow" on page 40](#)
- ["Power Supply Cooling System" on page 41](#)

During normal operation, the fans in the fan module operate at moderate or less than full speed. If a fan fails or the ambient temperature rises above a threshold, the cooling system of the switch automatically

adjusts the speed of the remaining fans. This speed adjustment helps to keep the temperature within the acceptable range. If the maximum temperature specification is exceeded and the system cannot be adequately cooled, the switch shuts down some or all of the hardware components.

## Fan Modules

The QFX5241-32OD have seven hot-insertable and hot-removable field-replaceable fan modules (QFX5241-1U-FAN-O) installed at the rear of the switch. Each fan tray module houses two 40 mm x 56 mm counter-rotating rotors. The cooling system offers N+1 redundancy at the rotor level.

You can remove and replace a fan module from the FRU end of the chassis. When you replace a fan when the switch is running, the switch continues to operate for a limited period of time (2 minutes) without thermal alarms or shutdown.

The fan modules in the QFX5241-32OD are FRUs designed for port-to-FRU airflow, which is also known as AFO or front-to-back airflow. The fan modules are numbered from **0** through **6**. Each fan module is 1-U high and has an associated LED to indicate its status.

**Figure 22: Fan Module for QFX5241-32OD Switch**

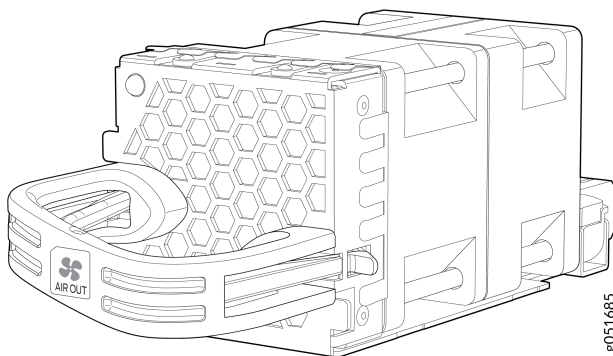

**NOTE:** The fan speed varies based on the temperature of internal components, optics modules, and the ambient temperature. The maximum speed at which fans operate depends on the ambient temperature that you have set. As the fan speed increases, the power consumed by the fans increases. As a result, the device consumes more power when the temperature is high because the fans run faster to maintain the operating temperature of the chassis within the configured limits.

The QFX5241-32OD switch must operate with all the seven fan modules installed. If you need to replace a faulty fan module, see "QFX5241-32OD Fan Module Status LED" on page 39.

### QFX5241-32OD Fan Module Status LED

Each fan module has one bicolor status LED.

Figure 23: Fan Module Components for QFX5241-32OD Switch

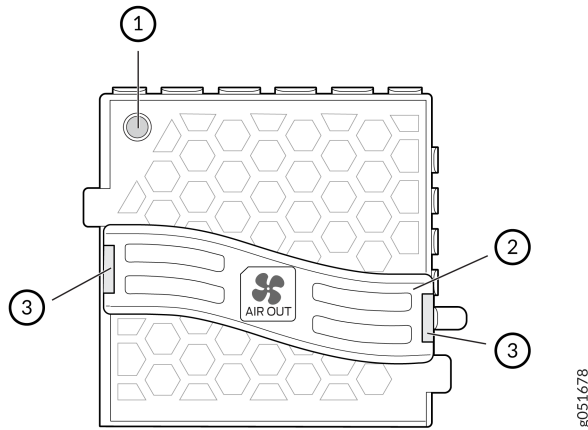

1- Fan module LED	3- Lock release handle
2- Handle	

Table 17 on page 40 describes the behavior of the fan module status LED.

Figure 24: Fan Module LED for QFX5241-32OD Switch

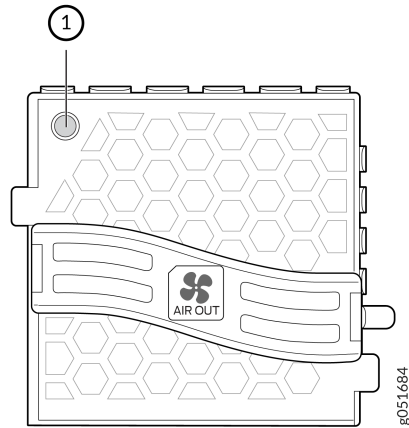

## 1– Fan module status LED

**Table 17: Fan Module Status LEDs**

Color	State	Description
Green	On steadily	Fan module is functioning normally.
Red	On steadily	Fan module is faulty and malfunctioning.
Unlit	Off	Fan module experiences input power failure.

Under normal operating conditions, the fan modules operate at a moderate speed. Temperature sensors in the chassis monitor the temperature within the chassis.

The system raises an alarm if a fan module fails or if the ambient temperature inside the chassis rises above the acceptable range. If the temperature inside the chassis rises above the threshold temperature, the system shuts down automatically.

### Airflow

The switch has a front-to-back (AFO) airflow design cooling system. The switch pulls air through the front of the chassis toward the fan modules, and exhausts the air from the rear of the switch.

Figure 25: AFO Airflow Through the QFX5241-32OD Chassis

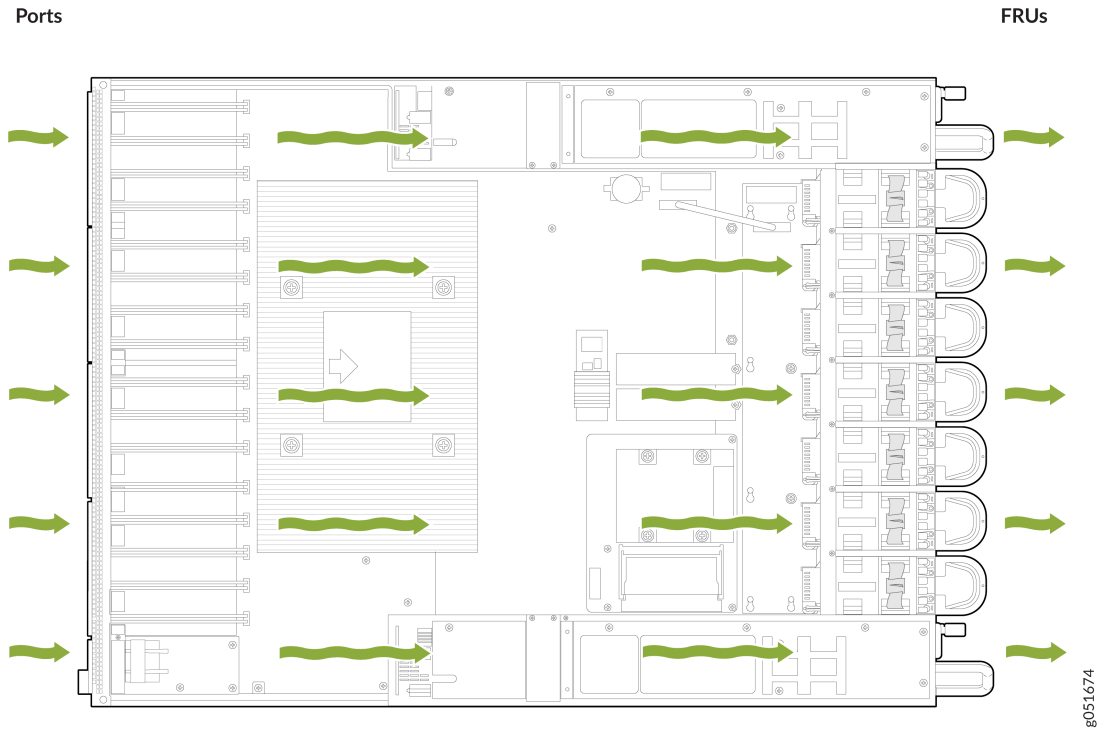

### Power Supply Cooling System

The QFX5241-32OD PSUs are installed at the rear of the chassis. The PSUs are self-cooling. Each PSU has its own fan and is cooled by its own internal cooling system. The PSUs in a QFX5241-32OD switch support front-to-back airflow (AFO).

# 3

CHAPTER

## Site Planning, Preparation, and Specifications

---

### IN THIS CHAPTER

- QFX5241-32OD Site Preparation Checklist | 43
  - QFX5241-32OD Site Guidelines and Requirements | 44
  - QFX5241-32OD Network Cables and Transceivers Planning | 52
  - QFX5241-32OD Management Cable Specifications and Pinouts | 57
-

# QFX5241-32OD Site Preparation Checklist

The checklist summarizes the tasks you need to perform when preparing a site for installing the QFX5241-32OD switch.

**Table 18: Site Preparation Checklist**

Item or Task	For More Information	Performed by	Date
<b>Environment</b>			
Verify that environmental factors such as temperature and humidity do not exceed switch tolerances.			
<b>Power</b>			
Measure the distance between external power sources and the switch installation site.			
Calculate the power consumption and requirements.			
<b>Rack or Cabinet</b>			
Verify that your rack or cabinet meets the minimum requirements for the installation of the switch.			
Plan rack or cabinet location, including required space clearances.			
Secure the rack or cabinet to the floor and building structure.			
<b>Cables</b>			

**Table 18: Site Preparation Checklist (Continued)**

Item or Task	For More Information	Performed by	Date
Acquire cables and connectors: <ul style="list-style-type: none"> <li>• Determine the number of cables needed based on your planned configuration.</li> <li>• Review the maximum distance allowed for each cable. Choose the length of cable based on the distance between the hardware components being connected.</li> </ul>			
Plan the cable routing and management.			

## QFX5241-32OD Site Guidelines and Requirements

### SUMMARY

Your QFX5241-32OD switch must meet the specified environmental requirements. The switch will function properly if you follow site and wiring guidelines. Ensure that your installation meets the grounding specifications and airflow clearance requirements.

### IN THIS SECTION

- [QFX5241-32OD Environmental Requirements and Specifications | 45](#)
- [General Site Guidelines | 46](#)
- [QFX5241-32OD Grounding Cable and Lug Specifications | 46](#)
- [QFX5241-32OD Clearance Requirements for Airflow and Hardware Maintenance | 48](#)
- [Site Electrical Wiring Guidelines | 48](#)
- [QFX5241-32OD Rack Requirements | 50](#)

## QFX5241-32OD Environmental Requirements and Specifications

You must install the switch in a rack. House it in a dry, clean, well-ventilated, and temperature-controlled environment.

Follow these environmental guidelines:

- The site must be as dust-free as possible. Dust can clog air intake vents and filters, thereby reducing the efficiency of the switch cooling system.
- Maintain ambient airflow to ensure normal operation of the switch. If the switch temperature is not maintained, the temperature monitor of the switch might shut down the device. The switch shuts down to protect its hardware components. The switch might overheat in the following scenarios:
  - The airflow is blocked or restricted
  - The intake air is too warm

**Table 19: QFX5241-32OD Switch Environmental Tolerance**

Description	Tolerance
Altitude	With DAC cables: At 32 °F (0 °C) through 104 °F (40 °C), no performance degradation occurs up to 6000 ft (1828.8 m)
	With optics: At 32 °F (0 °C) through 104 °F (40 °C), sea level
Relative humidity, operating	Normal operation ensured in the relative humidity range of 5% through 90%, noncondensing
Temperature	<ul style="list-style-type: none"> <li>• Normal operation ensured in the temperature range of 32 °F (0 °C) through 104 °F (40 °C).</li> <li>• nonoperating storage temperature in the shipping container: -40 °F (-40 °C) through 158 °F (70 °C)</li> </ul>
Acoustic noise level	83.37 dBA

## General Site Guidelines

Efficient device operation requires proper site planning. For the device to operate properly, you must ensure maintenance and proper layout of the equipment, rack or cabinet, and wiring closet.

To plan and create an acceptable operating environment for your device and prevent environmentally caused equipment failures:

- Keep the area around the chassis free from dust and conductive material, such as metal flakes.
- Follow the prescribed airflow guidelines to ensure that the cooling system functions properly. Ensure that the exhaust from other equipment does not blow into the intake vents of the device.
- Follow the prescribed electrostatic discharge (ESD) prevention procedures to prevent damaging the equipment. Static discharge can cause components to fail completely or intermittently over time.
- Install the device in a secure area, so that only authorized personnel can access the device.

## QFX5241-32OD Grounding Cable and Lug Specifications

For installations that need a separate chassis grounding conductor to the chassis, you must ground the chassis adequately before connecting power. Proper grounding of the chassis ensures operational correctness and compliance with safety and EMI requirements.

Ensure that you have a grounding cable and lug with the following specifications:

- Grounding cable—6 AWG , minimum 90 °C wire, or as permitted by the local code—not provided
- Grounding lug—Panduit LCD6-14A-L or equivalent grounding lug. The grounding lug attaches to the device chassis through the left-front mounting bracket, providing a protective earthing terminal for the device—not provided



**NOTE:** Ground the QFX5241-32OD switch to earth before you connect power to the device.

Figure 26: Grounding Cable and Lug for QFX5241-32OD Switch

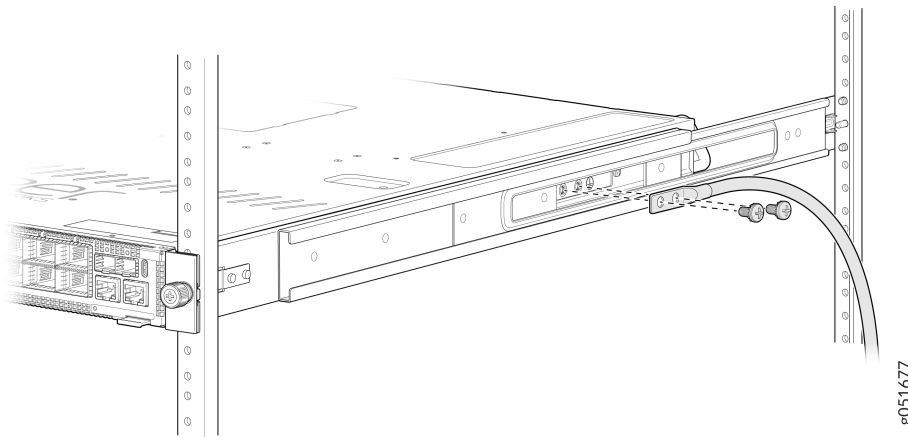

**WARNING:** The switch is pluggable type A equipment that is installed in a restricted-access location. The switch has a separate protective earthing terminal provided on the chassis in addition to the grounding pin of the power supply cord. You must permanently connect this separate protective earthing terminal to earth ground for installations that require a separate grounding conductor to the chassis.



**WARNING:** To comply with GR-1089 requirements, ensure that all intrabuilding copper cabling used for SFP+ and QSFP+ ports are shielded and grounded at both ends.



**CAUTION:** Before you install the switch, a licensed electrician must attach a cable lug to the grounding cables that you supply. A cable with an incorrectly attached lug can damage the switch.

Before connecting the switch to earth ground, review the following information:

- ["Clearance Requirements for Airflow and Hardware Maintenance" on page 48](#)
- ["Site Electrical Wiring Guidelines" on page 48](#)
- ["Rack Requirements" on page 50](#)

## QFX5241-32OD Clearance Requirements for Airflow and Hardware Maintenance

When planning the site for installing the QFX5241-32OD switch, you must allow sufficient clearance around the installed chassis. See [Figure 27 on page 48](#).

**Figure 27: Clearance Requirements for Airflow and Hardware Maintenance for QFX5241-32OD Switch**

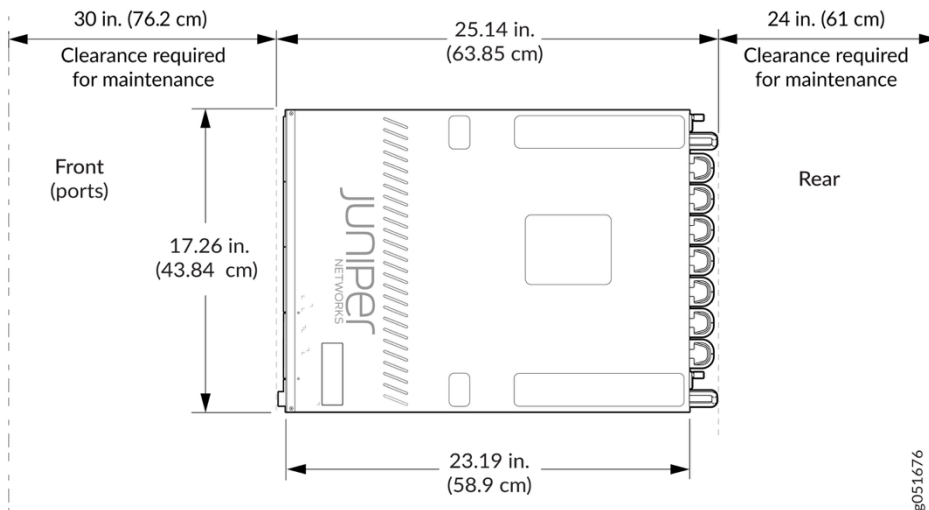

- For the cooling system to function properly, the airflow around the chassis must be unrestricted. See ["QFX5241-32OD Cooling System" on page 37](#) for more information about the airflow through the chassis.
- If you are mounting the QFX5241-32OD switch in a rack with other equipment, ensure that the exhaust from other equipments does not blow into the intake vents of the chassis.
- To facilitate service personnel movement, provision space of at least 24 in. (61 cm) both in the front and back of the switch.

## Site Electrical Wiring Guidelines

[Table 20 on page 49](#) describes the factors you must consider while planning the electrical wiring at your site.



**WARNING:** You must provide a properly grounded and shielded environment and use electrical surge-suppression devices.

**Avertissement** Vous devez établir un environnement protégé et convenablement mis à la terre et utiliser des dispositifs de parasurtension.

**Table 20: Site Electrical Wiring Guidelines**

Site Wiring Factor	Guidelines
Signaling limitations	<p>If your site experiences any of the following problems, consult experts in electrical surge suppression and shielding:</p> <ul style="list-style-type: none"> <li>• Radio frequency interference (RFI) because of improperly installed wires.</li> <li>• Damage from lightning strikes occurring when wires exceed recommended distances or pass between buildings.</li> <li>• Damage to unshielded conductors and electronic devices as a result of electromagnetic pulses (EMPs) caused by lightning.</li> </ul>
Radio frequency interference	<p>To reduce or eliminate RFI from your site wiring, do the following:</p> <ul style="list-style-type: none"> <li>• Use a twisted-pair cable with a good distribution of grounding conductors.</li> <li>• If you need to exceed the recommended distances, use a high-quality twisted-pair cable with one ground conductor for each data signal, when applicable.</li> </ul>
Electromagnetic compatibility	<p>If your site is susceptible to problems with electromagnetic compatibility (EMC), particularly from lightning or radio transmitters, seek expert advice.</p> <p>Strong sources of electromagnetic interference (EMI) can cause:</p> <ul style="list-style-type: none"> <li>• Destruction of the signal drivers and receivers in the device.</li> <li>• Electrical hazards as a result of power surges conducted over the lines into the equipment.</li> </ul>

## QFX5241-32OD Rack Requirements

You can install or mount the AC variant of QFX5241-32OD switch on a four-post rack using the QFX5241-1U-4PRMK toolless rack mount kit.

Rack requirements for installation using the QFX5241-1U-4PRMK consists of:

- Rack type
- Mounting bracket hole spacing
- Rack size and strength

**Table 21: Rack Requirements for the QFX5241-32OD Switch that Uses QFX5241-1U-4PRMK**

Rack Requirement	Guidelines
Rack type	<p>Use a four-post rack that provides bracket holes or hole patterns spaced at 1-U (1.75 in. or 4.45 cm) increments. The rack must meet the size and strength requirements to support the weight.</p> <p>A U is the standard rack unit defined in <i>Cabinets, Racks, Panels, and Associated Equipment</i> (document number EIA-310-D) published by the Electronics Industry Association.</p>
Mounting bracket hole spacing	<p>The holes in the mounting brackets are spaced at 1-U (1.75 in. or 4.45 cm) increments, so that the switch can be mounted in any four-post rack that provides holes spaced at that distance.</p>

**Table 21: Rack Requirements for the QFX5241-32OD Switch that Uses QFX5241-1U-4PRMK**  
*(Continued)*

Rack Requirement	Guidelines
Rack size and strength	<ul style="list-style-type: none"> <li>• Ensure that the rack complies with the standards for:               <ul style="list-style-type: none"> <li>• 19-in. rack as defined in <i>Cabinets, Racks, Panels, and Associated Equipment</i> (document number EIA-310-D) published by the Electronics Industry Association.</li> <li>• A 900-mm rack as defined in the four-part <i>Equipment Engineering (EE); European telecommunications standard for equipment practice</i> (document numbers ETS 300 119-1 through 119-4) published by the European Telecommunications Standards Institute.</li> </ul> </li> <li>• The horizontal spacing between the rails in a rack that complies with the European Telecommunications Standards is usually wider than the device's front-mounting brackets, which measure 19 in. (48.26 cm) from outer edge to outer edge. Use approved wing devices to narrow the opening between the rails as required.</li> <li>• Ensure that the rack rails are spaced widely enough to accommodate the external dimensions of the switch chassis. The outer edges of the front-mounting brackets extend the width to 19 in. (48.26 cm).</li> <li>• For four-post installations, the front and rear rack rails must be spaced between 25.6 in. (65 cm) and 31.5 in. (80 cm) front to back.</li> <li>• The rack must be strong enough to support the weight of the switch.</li> <li>• Ensure that the spacing of rails and adjacent racks allows for proper clearance around the switch and rack.</li> </ul>
Rack connection to building structure	<ul style="list-style-type: none"> <li>• Secure the rack to the building structure.</li> <li>• If your geographical area is earthquake-prone, then secure the rack to the floor.</li> <li>• Secure the rack to the ceiling brackets as well as wall or floor brackets for maximum stability.</li> </ul>

# QFX5241-32OD Network Cables and Transceivers Planning

## IN THIS SECTION

- Determine QFX5241-32OD Switch Optical Interface Support | 52
- Understand QFX Series Fiber-Optic Cable Signal Loss, Attenuation, and Dispersion | 53
- Calculate Power Budget and Power Margin for Fiber-Optic Cables | 54

## Determine QFX5241-32OD Switch Optical Interface Support

You can find information about the optical transceivers supported on your Juniper device by using the [Hardware Compatibility Tool](#). In addition to transceiver and connection type, the optical and cable characteristics, where applicable, are documented for each transceiver. The Hardware Compatibility Tool enables you to search by product, displaying all the transceivers supported on that device, or by category, displaying transceivers by interface speed or type.

For information about the optical transceivers and cables that are supported in QFX5241-32OD, see <https://apps.juniper.net/hct/home/>.



**CAUTION:** The Juniper Networks Technical Assistance Center (JTAC) provides complete support for Juniper-supplied optical modules and cables. However, JTAC does not provide support for third-party optical modules and cables that are not qualified or supplied by Juniper Networks. If you face a problem running a Juniper device that uses third-party optical modules or cables, JTAC may help you diagnose host-related issues if the observed issue is not, in the opinion of JTAC, related to the use of the third-party optical modules or cables. Your JTAC engineer will likely request that you check the third-party optical module or cable and, if required, replace it with an equivalent Juniper-qualified component.

Use of third-party optical modules with high-power consumption (for example, coherent ZR or ZR+) can potentially cause thermal damage to or reduce the lifespan of the host equipment. Any damage to the host equipment due to the use of third-party optical modules or cables is the users' responsibility. Juniper Networks will accept no liability for any damage caused due to such use.



**NOTE:** For interoperability with other QFX Series switches, ensure that autonegotiation is disabled on the QFX5241-32OD switch.

## Understand QFX Series Fiber-Optic Cable Signal Loss, Attenuation, and Dispersion

### IN THIS SECTION

- [Signal Loss in Multimode and Single-Mode Fiber-Optic Cables | 53](#)
- [Attenuation and Dispersion in Fiber-Optic Cable | 54](#)

To determine the power budget and power margin needed for fiber-optic connections, you need to understand how signal loss, attenuation, and dispersion affect transmission. The QFX Series uses various types of network cables, including multimode and single-mode fiber-optic cables.

### Signal Loss in Multimode and Single-Mode Fiber-Optic Cables

Multimode fiber is large enough in diameter to allow rays of light to reflect internally (bounce off the walls of the fiber). Interfaces with multimode optics typically use LEDs as light sources. However, LEDs are not coherent light sources. They spray varying wavelengths of light into the multimode fiber, which reflect the light at different angles. Light rays travel in jagged lines through a multimode fiber, causing signal dispersion. When light traveling in the fiber core radiates into the fiber cladding (layers of lower refractive index material in close contact with a core material of higher refractive index), higher-order mode loss occurs. Together, these factors reduce the transmission distance of multimode fiber compared to that of single-mode fiber.

Single-mode fiber is so small in diameter that rays of light reflect internally through one layer only. Interfaces with single-mode optics use lasers as light sources. Lasers generate a single wavelength of light, which travels in a straight line through the single-mode fiber. Compared to multimode fiber, single-mode fiber has a higher bandwidth and can carry signals for longer distances. It is consequently more expensive.

For information about the maximum transmission distance and supported wavelength range for the types of single-mode and multimode fiber-optic cables that are connected to the QFX Series, see [the](#)

[Hardware Compatibility Tool](#). Exceeding the maximum transmission distances can result in significant signal loss, which causes unreliable transmission.

## Attenuation and Dispersion in Fiber-Optic Cable

An optical data link functions correctly provided that modulated light reaching the receiver has enough power to be demodulated correctly. *Attenuation* is the reduction in strength of the light signal during transmission. Passive media components such as cables, cable splices, and connectors cause attenuation. Although attenuation is significantly lower for optical fiber than for other media, it still occurs in both multimode and single-mode transmission. An efficient optical data link must transmit enough light to overcome attenuation.

*Dispersion* is the spreading of the signal over time. The following two types of dispersion can affect signal transmission through an optical data link:

- Chromatic dispersion, which is the spreading of the signal over time caused by the different speeds of light rays.
- Modal dispersion, which is the spreading of the signal over time caused by the different propagation modes in the fiber.

For multimode transmission, modal dispersion, rather than chromatic dispersion or attenuation, usually limits the maximum bit rate and link length. For single-mode transmission, modal dispersion is not a factor. However, at higher bit rates and over longer distances, chromatic dispersion limits the maximum link length.

An efficient optical data link must have enough light to exceed the minimum power that the receiver requires to operate within its specifications. In addition, the total dispersion must be within the limits specified for the type of link in the Telcordia Technologies document GR-253-CORE (Section 4.3) and International Telecommunications Union (ITU) document G.957.

When chromatic dispersion is at the maximum allowed, its effect can be considered as a power penalty in the power budget. The optical power budget must allow for the sum of component attenuation, power penalties (including those from dispersion), and a safety margin for unexpected losses.

## Calculate Power Budget and Power Margin for Fiber-Optic Cables

### IN THIS SECTION

- [Calculate Power Budget for Fiber-Optic Cables](#) | 55

- [How to Calculate Power Margin for Fiber-Optic Cables](#) | 55

Use the information in this topic and the specifications for your optical interface to calculate the power budget and power margin for fiber-optic cables.



**TIP:** You can use the [Hardware Compatibility Tool](#) to find information about the pluggable transceivers supported on your Juniper Networks device.

To calculate the power budget and power margin, perform the following tasks:

### Calculate Power Budget for Fiber-Optic Cables

To ensure that fiber-optic connections have sufficient power for correct operation, you need to calculate the link's power budget ( $P_B$ ), which is the maximum amount of power it can transmit. When you calculate the power budget, you use a worst-case analysis to provide a margin of error, even though all the parts of an actual system do not operate at the worst-case levels. To calculate the worst-case estimate of  $P_B$ , you assume minimum transmitter power ( $P_T$ ) and minimum receiver sensitivity ( $P_R$ ):

$$P_B = P_T - P_R$$

The following hypothetical power budget equation uses values measured in decibels (dB) and decibels referred to one milliwatt (dBm):

$$P_B = P_T - P_R$$

$$P_B = -15 \text{ dBm} - (-28 \text{ dBm})$$

$$P_B = 13 \text{ dB}$$

### How to Calculate Power Margin for Fiber-Optic Cables

After calculating a link's  $P_B$ , you can calculate the power margin ( $P_M$ ), which represents the amount of power available after subtracting attenuation or link loss (LL) from the  $P_B$ . A worst-case estimate of  $P_M$  assumes maximum LL:

$$P_M = P_B - LL$$

$P_M$  greater than zero indicates that the power budget is sufficient to operate the receiver.

Factors that can cause link loss include higher-order mode losses, modal and chromatic dispersion, connectors, splices, and fiber attenuation. [Table 22 on page 56](#) lists an estimated amount of loss for the

factors used in the following sample calculations. For information about the actual amount of signal loss caused by equipment and other factors, refer to vendor documentation.

**Table 22: Estimated Values for Factors Causing Link Loss**

Link-Loss Factor	Estimated Link-Loss Value
Higher-order mode losses	Single mode—None Multimode—0.5 dB
Modal and chromatic dispersion	Single mode—None Multimode—None, if product of bandwidth and distance is less than 500 MHz-km
Faulty connector	0.5 dB
Splice	0.5 dB
Fiber attenuation	Single mode—0.5 dB/km Multimode—1 dB/km

The following sample calculation for a 2-km-long multimode link with a  $P_B$  of 13 dB uses the estimated values from [Table 22 on page 56](#). This example calculates LL as the sum of fiber attenuation (2 km @ 1 dB/km, or 2 dB) and loss for five connectors (0.5 dB per connector, or 2.5 dB) and two splices (0.5 dB per splice, or 1 dB) as well as higher-order mode losses (0.5 dB). The  $P_M$  is calculated as follows:

$$P_M = P_B - LL$$

$$P_M = 13 \text{ dB} - 2 \text{ km} (1 \text{ dB/km}) - 5 (0.5 \text{ dB}) - 2 (0.5 \text{ dB}) - 0.5 \text{ dB}$$

$$P_M = 13 \text{ dB} - 2 \text{ dB} - 2.5 \text{ dB} - 1 \text{ dB} - 0.5 \text{ dB}$$

$$P_M = 7 \text{ dB}$$

The following sample calculation for an 8-km-long single-mode link with a  $P_B$  of 13 dB uses the estimated values from [Table 22 on page 56](#). This example calculates LL as the sum of fiber attenuation (8 km @ 0.5 dB/km, or 4 dB) and loss for seven connectors (0.5 dB per connector, or 3.5 dB). The  $P_M$  is calculated as follows:

$$P_M = P_B - LL$$

$$P_M = 13 \text{ dB} - 8 \text{ km} (0.5 \text{ dB/km}) - 7(0.5 \text{ dB})$$

$$P_M = 13 \text{ dB} - 4 \text{ dB} - 3.5 \text{ dB}$$

$$P_M = 5.5 \text{ dB}$$

In both the examples, the calculated  $P_M$  is greater than zero, indicating that the link has sufficient power for transmission and does not exceed the maximum receiver input power.

## QFX5241-32OD Management Cable Specifications and Pinouts

### IN THIS SECTION

- [Cable Specifications for Console and Management Connections for the QFX Series | 57](#)
- [RJ-45 Management Port Connector Pinout Information | 58](#)
- [Console Port Connector Pinouts for the QFX Series | 59](#)
- [OSFP Port Connector Pinout Information | 60](#)
- [SFP, SFP+, and SFP28 Port Connector Pinout Information | 64](#)
- [USB Port Specifications for the QFX Series | 65](#)

### Cable Specifications for Console and Management Connections for the QFX Series

[Table 23 on page 58](#) lists the specifications for the cables that connect the QFX Series switch to a management device.



**NOTE:** The QFX Series switches have small form-factor pluggable (SFP) management ports that support 1000BASE-SX transceivers. QFX switches come with a RJ-45 management port, and support 10-Gbps speed. See the [Hardware Compatibility Tool](#) for more information about the fiber-optic cables required for use with these transceivers.

**Table 23: Cable Specifications for Console and Management Connections for the QFX Series**

Port on QFX Series Device	Cable Specification	Maximum Length	Device Receptacle
Console port	RS-232 (EIA-232) serial cable	7 ft (2.13 m)	RJ-45
Management port	Category 5 cable or equivalent suitable for 1000BASE-T operation	328 ft (100 m)	RJ-45



**NOTE:** We no longer include the RJ-45 console cable with the DB-9 adapter as part of the device package. If the console cable and adapter are not included in your device package, or if you need a different type of adapter, you can order the following separately:

- RJ-45 to DB-9 adapter (JNP-CBL-RJ45-DB9)
- RJ-45 to USB-A adapter (JNP-CBL-RJ45-USBA)
- RJ-45 to USB-C adapter (JNP-CBL-RJ45-USBC)

If you want to use RJ-45 to USB-A or RJ-45 to USB-C adapter you must have X64 (64-Bit) Virtual COM port (VCP) driver installed on your PC. See, <https://ftdichip.com/drivers/vcp-drivers/> to download the driver.

## RJ-45 Management Port Connector Pinout Information

Table 24 on page 58 provides the pinout information for the RJ-45 connector for the management port on Juniper Networks devices.

**Table 24: RJ-45 Management Port Connector Pinout Information**

Pin	Signal	Description
1	TRP1+	Transmit/receive data pair 1
2	TRP1-	Transmit/receive data pair 1

Table 24: RJ-45 Management Port Connector Pinout Information (*Continued*)

Pin	Signal	Description
3	TRP2+	Transmit/receive data pair 2
4	TRP3+	Transmit/receive data pair 3
5	TRP3-	Transmit/receive data pair 3
6	TRP2-	Transmit/receive data pair 2
7	TRP4+	Transmit/receive data pair 4
8	TRP4-	Transmit/receive data pair 4

## Console Port Connector Pinouts for the QFX Series

The console port (labeled **CON** or **CONSOLE**) is an RS-232 serial interface that uses an RJ-45 connector to connect to a console management device. The default baud rate for the console port is 9600 baud. You can also use a RJ45 to USB 2.0 Type-A cable and a RJ45 to USB 2.0 Type-C cable.

Table 25 on page 60 provides the pinout information for the RJ-45 console connector.



**NOTE:** If your laptop or PC does not have a DB-9 plug connector pin and you want to connect your laptop or PC directly to a QFX Series device, use a combination of an RJ-45 to DB-9 adapter and a USB to DB-9 plug adapter. You must provide the USB to DB-9 plug adapter.



**NOTE:** We no longer include the RJ-45 console cable with the DB-9 adapter as part of the device package. If the console cable and adapter are not included in your device package, or if you need a different type of adapter, you can order the following separately:

- RJ-45 to DB-9 adapter (JNP-CBL-RJ45-DB9)
- RJ-45 to USB-A adapter (JNP-CBL-RJ45-USBA)
- RJ-45 to USB-C adapter (JNP-CBL-RJ45-USBC)

If you want to use RJ-45 to USB-A or RJ-45 to USB-C adapter you must have X64 (64-Bit) Virtual COM port (VCP) driver installed on your PC. See, <https://ftdichip.com/drivers/vcp-drivers/> to download the driver.

**Table 25: Console Port Connector Pinouts for the QFX Series**

Pin	Signal	Description
3	TxD Output	Transmit data
4	Signal Ground	Signal ground
5	Signal Ground	Signal ground
6	RxD Input	Receive data

## OSFP Port Connector Pinout Information

Table 26 on page 60 provides the pinout mapping for Octal small form factor pluggable (OSFP) port connectors.

**Table 26: OSFP Network Port Pinout Mapping**

Pin	Symbol	Description
1	GND	Ground
2	TX2p	Transmitter data non-inverted CML-I
3	TX2n	Transmitter data inverted CML-I

Table 26: OSFP Network Port Pinout Mapping (Continued)

Pin	Symbol	Description
4	GND	Ground
5	TX4p	Transmitter data non-inverted CML-I
6	TX4n	Transmitter data inverted CML-I
7	GND	Ground
8	TX6p	Transmitter data non-inverted CML-I
9	TX6n	Transmitter data inverted CML-I
10	GND	Ground
11	TX8p	Transmitter data non-inverted CML-I
12	TX8n	Transmitter data inverted CML-I
13	GND	Ground
14	SCL	2-wire serial interface clock LVCMOS-I/O
15	VCC	+3.3V power
16	VCC	+3.3V power
17	LPWn/PRSn	Low-power mode/module present
18	GND	Ground
19	RX7n	Receiver data inverted CML-O
20	RX7p	Receiver data non-inverted CML-O
21	GND	Ground
22	RX5n	Receiver data inverted CML-O

Table 26: OSFP Network Port Pinout Mapping (Continued)

Pin	Symbol	Description
23	RX5p	Receiver data non-inverted CML-O
24	GND	Ground
25	RX3n	Receiver data inverted CML-O
26	RX3p	Receiver data non-inverted CML-O
27	GND	Ground
28	RX1n	Receiver data inverted CML-O
29	RX1p	Receiver data non-inverted CML-O
30	GND	Ground
31	GND	Ground
32	RX2p	Receiver data non-inverted CML-O
33	RX2n	Receiver data inverted CML-O
34	GND	Ground
35	RX4p	Receiver Data Non-Inverted CML-O
36	RX4n	Receiver data inverted CML-O
37	GND	Ground
38	RX6p	Receiver data non-inverted CML-O
39	RX6n	Receiver data inverted CML-O
40	GND	Ground
41	RX8p	Receiver data non-inverted CML-O

Table 26: OSFP Network Port Pinout Mapping (Continued)

Pin	Symbol	Description
42	RX8n	Receiver data inverted CML-O
43	GND	Ground
44	INT/RSTn	Module interrupt/module reset
45	VCC	+3.3V power
46	VCC	+3.3V power
47	SDA	2-wire serial interface data LVCMOS-I/O
48	GND	Ground
49	TX7n	Transmitter data inverted CML-I
50	TX7p	Transmitter data non-inverted CML-I
51	GND	Ground
52	TX5n	Transmitter data inverted CML-I
53	TX5p	Transmitter data non-inverted CML-I
54	GND	Ground
55	TX3n	Transmitter data inverted CML-I
56	TX3p	Transmitter data non-inverted CML-I
57	GND	Ground
58	TX1n	Transmitter data inverted CML-I
59	TX1p	Transmitter data non-inverted CML-I
60	GND	Ground

## SFP, SFP+, and SFP28 Port Connector Pinout Information

Table 27 on page 64 provides the pinout mapping for small-form factor pluggable (SFP) connectors, SFP+ connectors, and SFP28 connectors.

**Table 27: SFP, SFP+, and SFP28 Port Connector Pinout Mapping**

Pin	Symbol	Description
1	VeeT	Transmitter ground
2	TX_Fault	Transmitter fault indication
3	TX_Disable	Optical output disabled when high
4	SDA	2-wire serial interface data (MOD-DEF2)
5	SCA	2-wire serial interface data (MOD-DEF1)
6	MOD_ABS	Module absent
7	RS0	Receiver rate select
8	RX_LOS	Receiver loss of signal indication
9	RS1	Transmitter rate select
10	VeeR	Receiver ground
11	VeeR	Receiver ground
12	RD-	Receiver inverted DATA out
13	RD+	Receiver non-inverted DATA out

Table 27: SFP, SFP+, and SFP28 Port Connector Pinout Mapping (Continued)

Pin	Symbol	Description
14	VeeR	Receiver ground
15	VccR	Receiver power supply
16	VccT	Transmitter power supply
17	VeeT	Transmitter ground
18	TD+	Transmitter non-inverted DATA in
19	TD-	Transmitter inverted DATA in
20	VeeT	Transmitter ground

## USB Port Specifications for the QFX Series

The following Juniper Networks USB flash drives have been tested and are officially supported for the USB port in QFX Series devices:

- RE-USB-2G-S—2-GB USB flash drive
- RE-USB-4G-S—4-GB USB flash drive



**CAUTION:** Any USB memory product not listed as supported for the QFX Series has not been tested by Juniper Networks. The use of any unsupported USB memory product could expose your device to unpredictable behavior. Juniper Networks Technical Assistance Center (JTAC) can provide only limited support for issues related to unsupported hardware. We strongly recommend that you use only supported USB flash drives.



**CAUTION:** Remove the USB flash drive before upgrading Junos OS or rebooting a QFX Series device. Failure to do so could expose your device to unpredictable behavior.



**NOTE:** USB flash drives used with the QFX Series device must support USB 2.0 or later.

# 4

CHAPTER

## Initial Installation and Configuration

---

### IN THIS CHAPTER

- [Unpack and Mount the QFX5241-32OD Switch | 68](#)
  - [Connect the QFX5241-32OD Switch to Power | 81](#)
  - [Connect the QFX5241 Switch to External Devices | 85](#)
  - [Perform Initial Software Configuration for QFX5241-32OD Switch | 88](#)
-

# Unpack and Mount the QFX5241-32OD Switch

## IN THIS SECTION

- Unpack QFX5241-32OD Switch | 68
- Register Products—Mandatory to Validate SLAs | 70
- Mount the QFX5241-32OD Switch on a Square Hole Rack by Using the QFX5241-1U-4PRMK Rack Mount Kit | 71
- Mount Your QFX5241-32OD Switch on a Threaded-Hole Rack by Using the QFX5241-1U-4PRMK Rack Mount Kit | 75

## Unpack QFX5241-32OD Switch

The chassis of QFX5241-32OD switch is a rigid sheet-metal structure that houses the hardware components. We ship the QFX5241-32OD switch in a cardboard carton, secured with foam packing material.



**CAUTION:** The QFX5241-32OD switch is maximally protected inside the shipping carton. Do not unpack the switch until you are ready to begin installation.

To unpack the QFX5241-32OD switch:

1. Move the shipping carton to a staging area as close to the installation site as possible, but where you have enough room to remove the system components.
2. Position the carton so that the arrows are pointing up.
3. Open the top flaps on the shipping carton.
4. Remove the switch out of the packing material from the pellet.
5. Verify the contents of the carton against the inventory included in the carton. [Table 28 on page 69](#) lists the inventory of components supplied with the QFX5241-32OD.
6. Save the shipping carton and packing materials in case you need to move or ship the switch later.

**Table 28: Inventory of Components Supplied with QFX5241-32OD Switch**

Component	Quantity
Chassis	1
Fan modules	7, factory installed
Power supply units (PSUs):	2, factory installed
<ul style="list-style-type: none"> <li>QFX5241-1U-PWR-AO</li> </ul>	
<ul style="list-style-type: none"> <li>Rack mount kit, QFX5241-1U-4PRMK, for the following switch variants: <ul style="list-style-type: none"> <li>QFX5241-32OD-AO</li> </ul> </li> </ul> <p><b>NOTE:</b> The order number for a spare rack mount kit is QFX5241-1U-4PRMK.</p>	1
Rack mount kit, QFX5241-1U-4PRMK, is composed of the following:	
Chassis brackets	2
Rear floating rail	2
Front rail	2
Rack mount assembly drawing (part of the QFX5241-1U-4PRMK rack mount kit)	1
Power cords with plugs appropriate to your geographical location	2
Documentation roadmap card	1
Warranty	1

**NOTE:**

- For QFX5241-32OD switch with AC power supplies, two power cords (*CG\_CBL-SDG-C20-2M*) of 2 m length ship with the switch by default.



**NOTE:** We no longer include the RJ-45 console cable with the DB-9 adapter as part of the device package. If the console cable and adapter are not included in your device package, or if you need a different type of adapter, you can order the following separately:

- RJ-45 to DB-9 adapter (JNP-CBL-RJ45-DB9)
- RJ-45 to USB-A adapter (JNP-CBL-RJ45-USBA)
- RJ-45 to USB-C adapter (JNP-CBL-RJ45-USBC)

If you want to use RJ-45 to USB-A or RJ-45 to USB-C adapter you must have X64 (64-Bit) Virtual COM port (VCP) driver installed on your PC. See, <https://ftdichip.com/drivers/vcp-drivers/> to download the driver.

## Register Products—Mandatory to Validate SLAs

Juniper Networks auto registers newly purchased products based on the end customer information provided at the point of sale. Registering products and changes to products activates your hardware replacement service-level agreements (SLAs).



**CAUTION:** Update the installation base data if any installation base data is added or changed or if the installation base is moved. Juniper Networks is not responsible for customers not meeting the hardware replacement service-level agreement (SLA) for products that do not have registered serial numbers or accurate installation base data. To know more about how to register your product and update your installation base, see [Juniper Networks Product Registration and Install Base Management](#).

## Mount the QFX5241-32OD Switch on a Square Hole Rack by Using the QFX5241-1U-4PRMK Rack Mount Kit

Ensure that you have the following tools and parts available:

- An ESD grounding strap (not provided)
- A pair of front-mounting and rear-mounting rails

These mounting rails attach to the front and rear rack posts (provided with the RMK)

- A pair of side-mounting brackets—provided with the RMK

You must attach these brackets to the device.

To mount the device on four posts in a rack by using the QFX5241-1U-4PRMK:

1. Review the [General Safety Guidelines and Warnings](#).
2. Wrap and fasten the ESD grounding strap to your bare wrist, and connect the other end of the strap to the ESD point on the device.
3. To attach the side-mounting brackets to the chassis, align the keyholes on the mounting brackets over the shoulder screws on the chassis. Slide the mounting brackets toward the rear of the chassis.

**Figure 28: Attach the Side-Mounting Brackets to the Chassis**

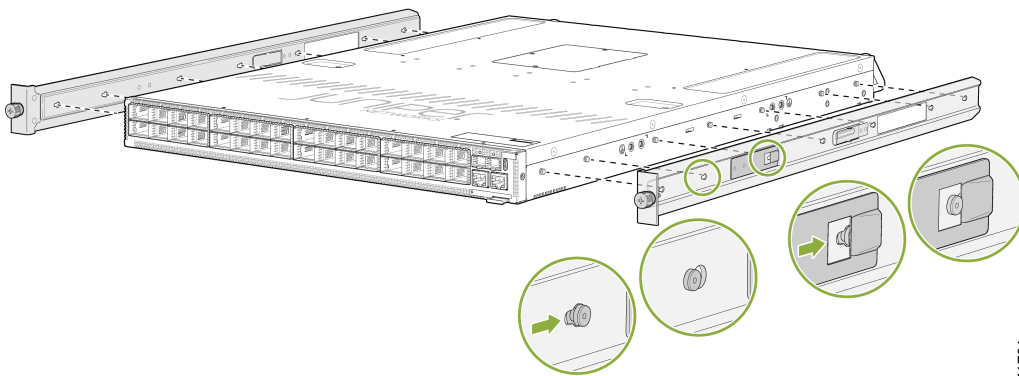

8051701

4. You can also flush mount the chassis on the rear side.

Figure 29: Flush Mount the Chassis from Rear Side

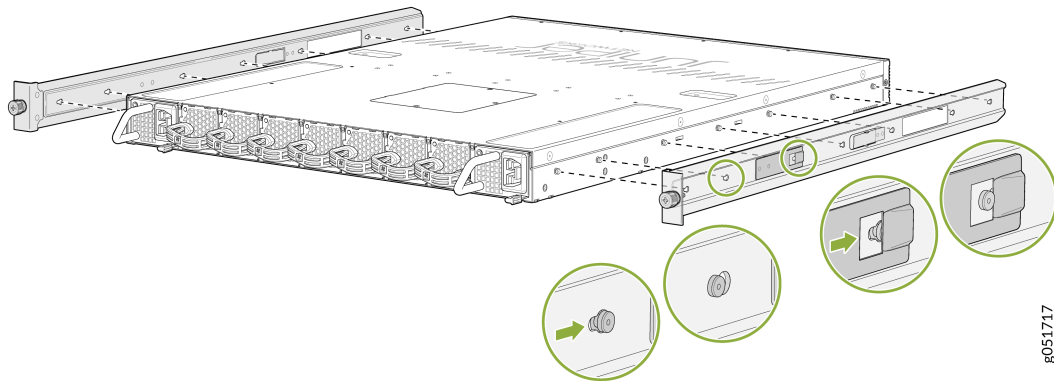

**NOTE:** Flip the rails when you flush mount the chassis on the rear side.

5. Assemble the mounting rails by sliding the rear floating rails into the front rails.

Figure 30: Assemble the Front and Rear Mounting Rails

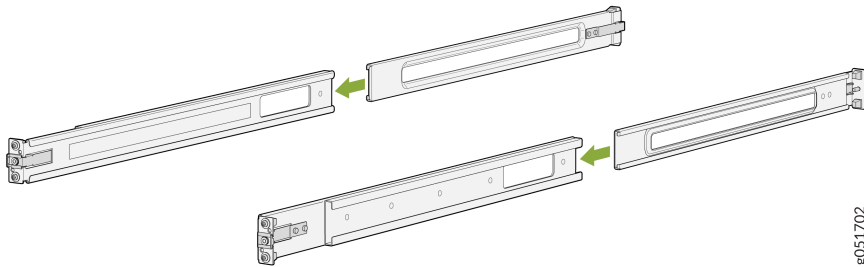

6. Attach the mounting rails to the rack.
  - a. Standing in front of the rack, align the guide blocks of the rear-mounting rails with the rear-post holes. Pull the rear-mounting rails toward the front of the rack to lock the rails in place. You will hear a click sound when the latch locks into the corresponding rack holes.

**Figure 31: Install the Rear Floating Rails**

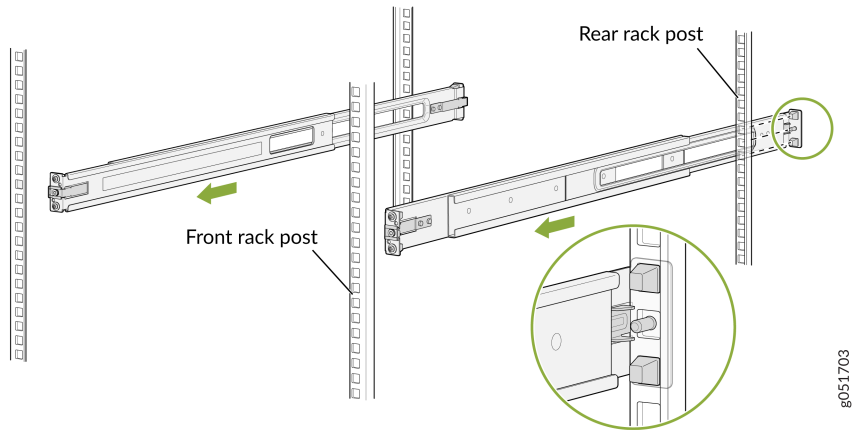

- b. Move the latch lock on the front-mounting rail to open position, slide the front-mounting rail, and insert the guide blocks into the front rack posts.

**Figure 32: Attach the Front Mounting Rails to the Rack Posts**

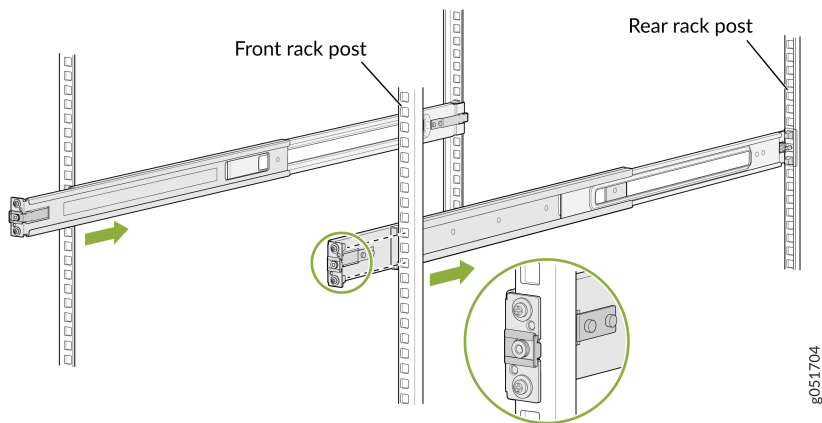

- c. Ensure that the front and rear latches on the mounting rails are locked in place. The mounting rails are now fully installed.

**Figure 33: Mounting Rails Fully Installed**

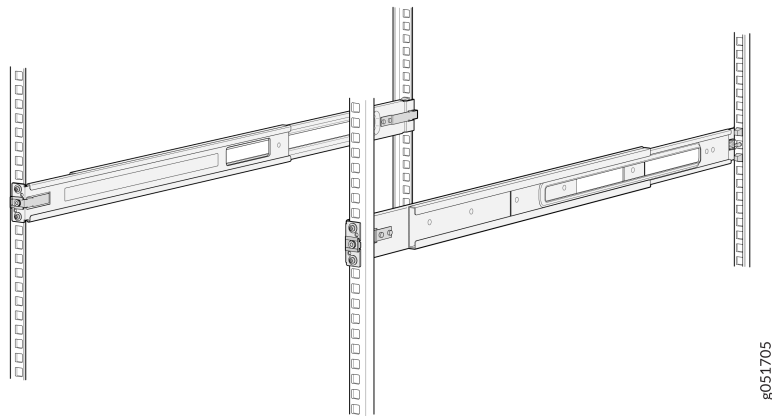

7. Lift the device and position it in the rack, aligning the side-mounting brackets with the mounting rails. Slide the device into the channels of the mounting rails.

**Figure 34: Attach the QFX5241-32OD Chassis to the Rack**

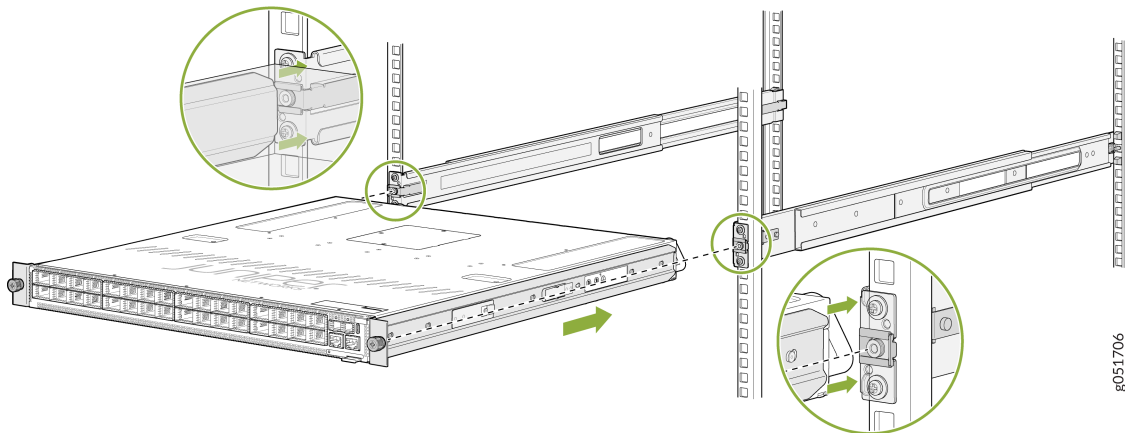

8. Tighten the two thumbscrews to secure the switch.

Figure 35: Tighten the Thumbscrews

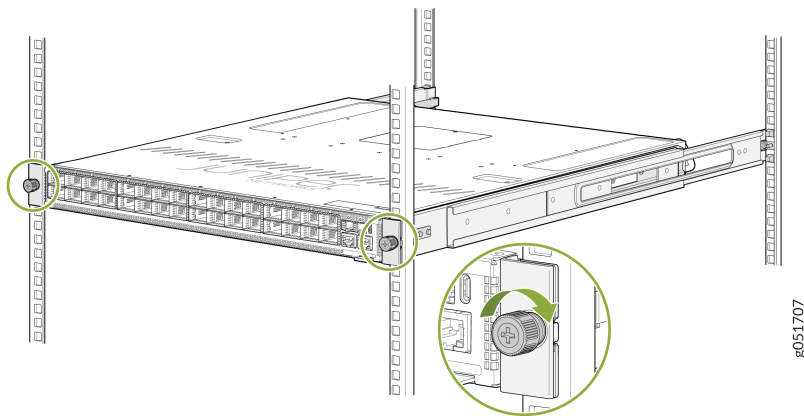

## Mount Your QFX5241-32OD Switch on a Threaded-Hole Rack by Using the QFX5241-1U-4PRMK Rack Mount Kit

You can mount the QFX5241-32OD switch in a four-post threaded-hole rack within a cabinet. Ensure that you have the following tools and parts available:

- An ESD grounding strap (not provided)
- A Phillips (+) screwdriver, number 2—not provided
- A pair of side-mounting brackets that attach to the chassis [provided with the rack mount kit (RMK)]
- A pair of front-mounting and rear-mounting rails that attach to the rack posts (provided with the RMK)

To mount the device on a four-post rack with threaded holes:

1. Review the [General Safety Guidelines and Warnings](#).
2. Wrap and fasten one end of the electrostatic discharge (ESD) cable grounding strap around your bare wrist, and connect the other end to a site ESD point.
3. To attach the side-mounting brackets to the chassis, align the keyholes on the mounting brackets over the shoulder screws on the chassis. Slide the mounting brackets toward the rear of the chassis.

**Figure 36: Attach the Side-Mounting Brackets**

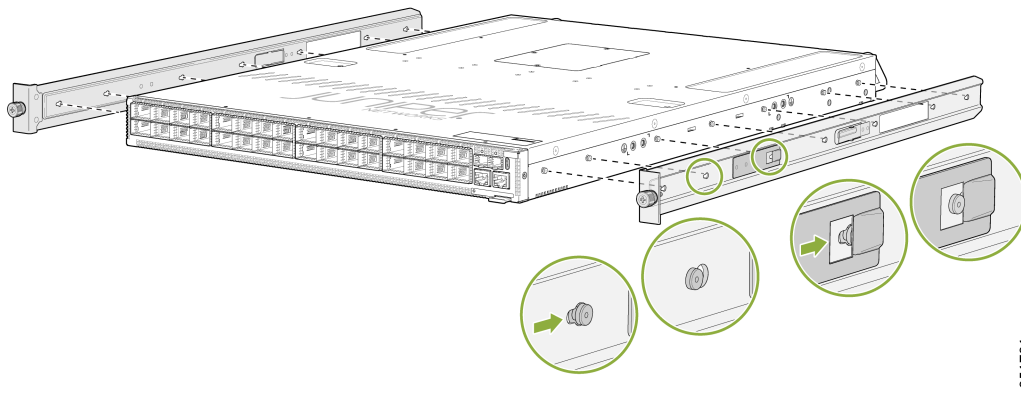

4. You can also flush mount the chassis on the rear side.

**Figure 37: Flush Mount the Chassis from Rear Side**

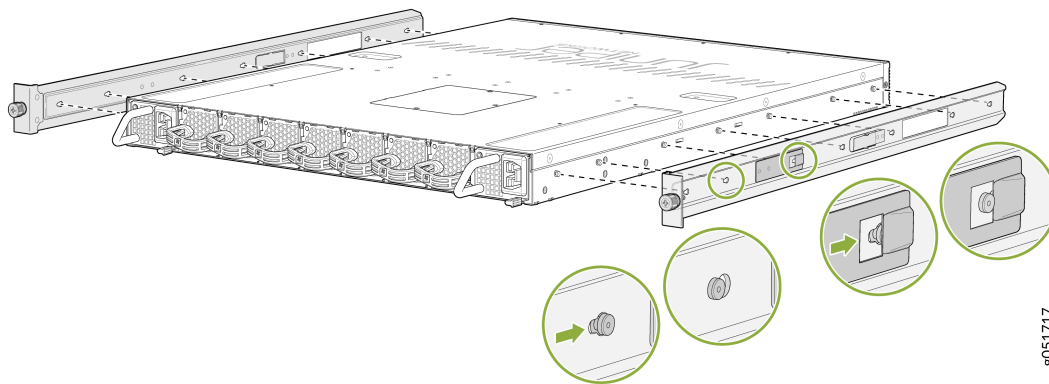

5. Assemble the mounting rails:
- a. Remove the guide blocks from the front-mounting rails by loosening the screws and washers. Retain the guide blocks, screws, and washers for later use.

**Figure 38: Remove the Guide Blocks from the Front Mounting Rail**

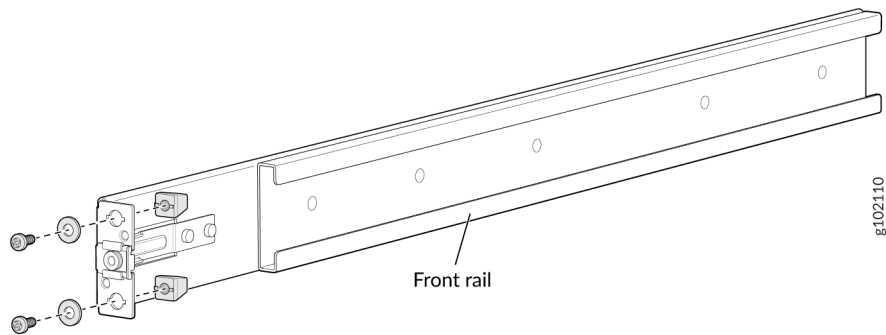

- b. Remove the guide blocks from the rear-mounting rail by loosening the screws and washers. Retain the guide blocks, screws, and washers for later use.

**Figure 39: Remove the Guide Blocks from the Rear-Mounting Rail**

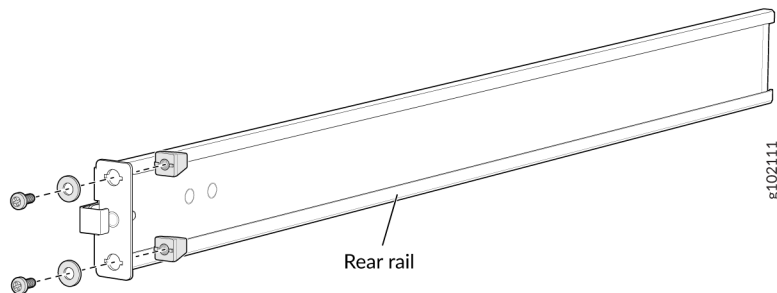

- c. Slide the rear floating rails into the front rails.

**Figure 40: Assemble the Mounting Rails**

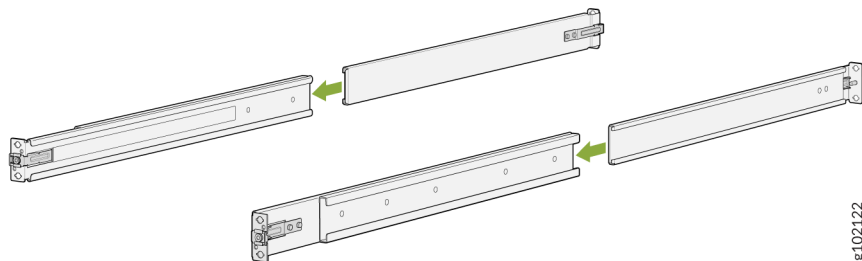

6. Install the mounting rails on the rack:

- a. Insert the guide pin of the rear-mounting rails into the rear-post holes. Pull the rear-mounting rails toward the front of the rack to lock the rails in place. You will hear a distinct click sound when the latch locks into place.

**Figure 41: Install the Rear-Mounting Rails**

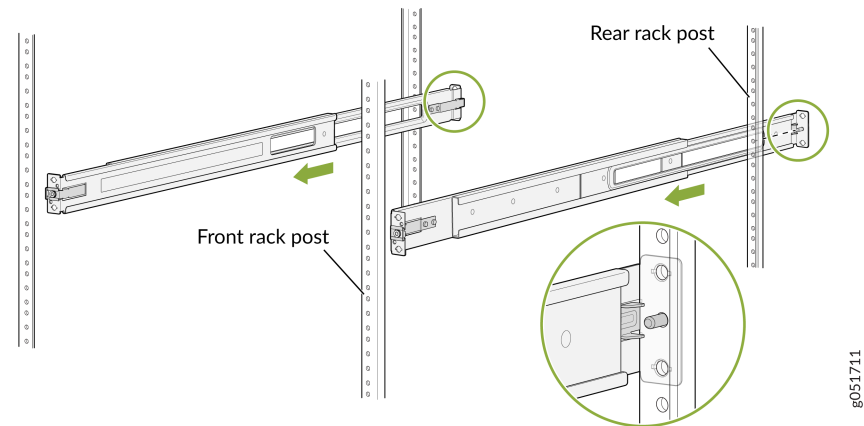

- b. Insert the guide pin of the front-mounting rails into the front-post holes. Push the front-mounting rails toward the rear of the rack to lock the rails in place. You will hear a distinct click sound when the latch locks into place. Secure the front-mounting rails to the front rack post by using screws (not provided) appropriate for your rack threaded size.

**Figure 42: Install and Secure the Front-Mounting Rails**

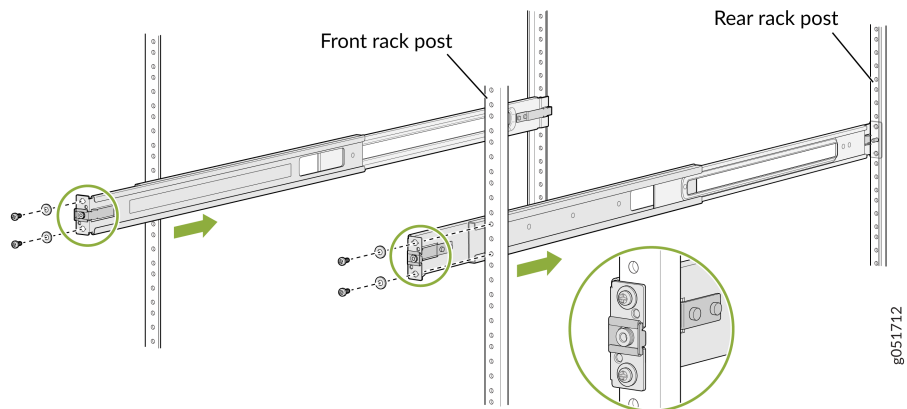

- c. Secure the front-mounting rails to the front rack post by using screws (not provided) appropriate for your rack threaded size.

**Figure 43: Secure the Rear-Mounting Brackets**

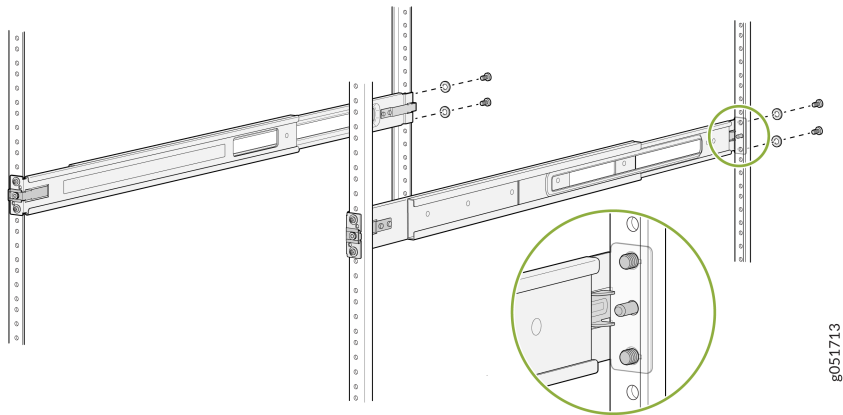

- d. Ensure that the front and rear latches are locked into place on the mounting rails. The mounting rails must be securely installed on the rack.

**Figure 44: Mounting Rails Installed and Secured**

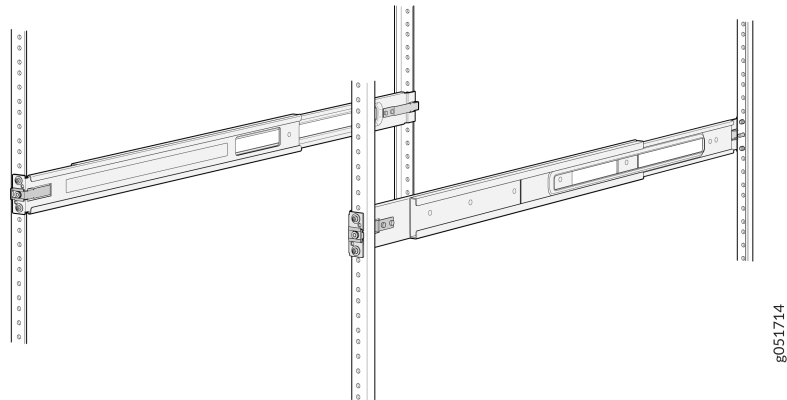

7. Lift the device and position it in the rack, aligning the side-mounting brackets with the mounting rails. Slide the device into the channels of the mounting rails.

Figure 45: Slide the Device into the Rack

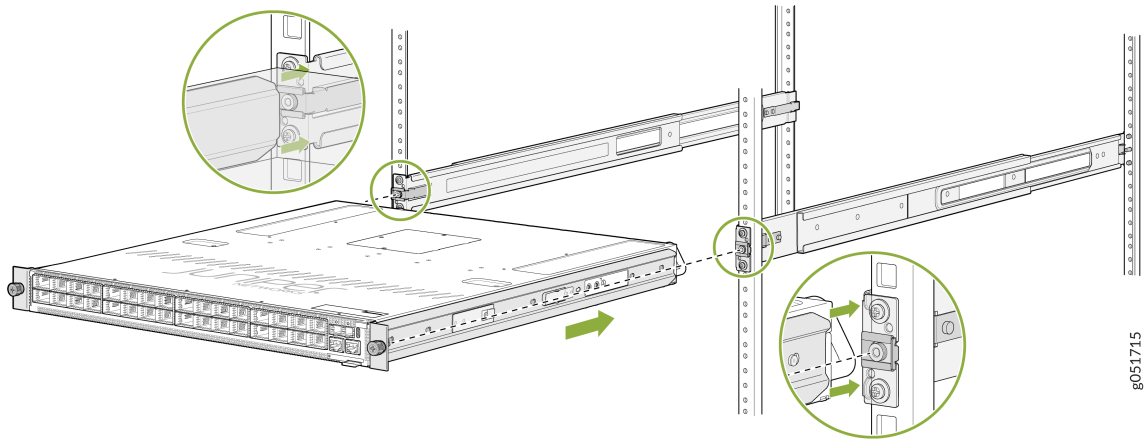

- 8. Tighten the two thumbscrews to secure the device.

Figure 46: Tighten the Thumbscrews

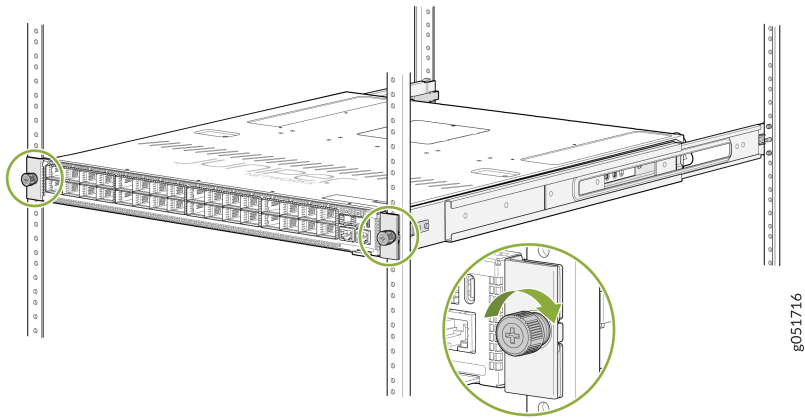

# Connect the QFX5241-32OD Switch to Power

## IN THIS SECTION

- [Ground the QFX5241-32OD Switch | 81](#)
- [Connect AC Power to QFX5241-32OD Switch | 83](#)

## Ground the QFX5241-32OD Switch

You must connect the QFX5241-32OD switch to earth ground before you connect it to power. Grounding helps your switch meet safety and EMI requirements and ensures that the switch functions properly.

You must install the QFX5241-32OD switch in a restricted-access location and ensure that the chassis is always properly grounded. The QFX5241-32OD switch comes with a two-hole protective grounding terminal provided on the side of the chassis. See [Figure 47 on page 82](#). Under all circumstances, use this grounding connection to ground the chassis. For AC-powered systems, you must also use the grounding wire in the AC power cord along with the two-hole grounding lug connection. The system is tested to ensure that it meets or exceeds all applicable EMC regulatory requirements for the two-hole protective grounding terminal.



**CAUTION:** Ensure that a licensed electrician has attached an appropriate grounding lug to the grounding cable that you supply. Using a grounding cable with an incorrectly attached lug can damage the device.



**NOTE:** Install your switch in the rack before attaching the grounding lug to the switch.

Ensure that you have the following parts and tools available:

- A grounding cable (not provided)—6 AWG, minimum 90 °C wire, or as permitted by the local code.
- A grounding lug (not provided)—Panduit LCD6-14A-L or equivalent grounding lug. The grounding lug attaches to the device chassis through the left-front mounting bracket, providing a protective earthing terminal for the device.
- Two M6 screws, 6 mm length with star washers (not provided)

- Phillips (+) screwdriver, number 2
- ESD grounding strap (not provided)

To ground the QFX5241-32OD switch:

1. Wrap and fasten one end of the electrostatic discharge (ESD) grounding strap around your bare wrist, and connect the other end to a site ESD point or to the ESD point on your device.
2. Remove the two M6 screws with star washers from the earthing terminal on the sides of the chassis.
3. Place the Panduit LCD6-14A-L or equivalent grounding lug attached to the grounding cable over the protective earthing terminal. Attach the lug through the left-mounting bracket to the chassis.
4. Secure the grounding lug to the protective earthing terminal using the two M6 screws with star washers.

**Figure 47: Connect a Grounding Cable to the QFX5241-32OD Switch**

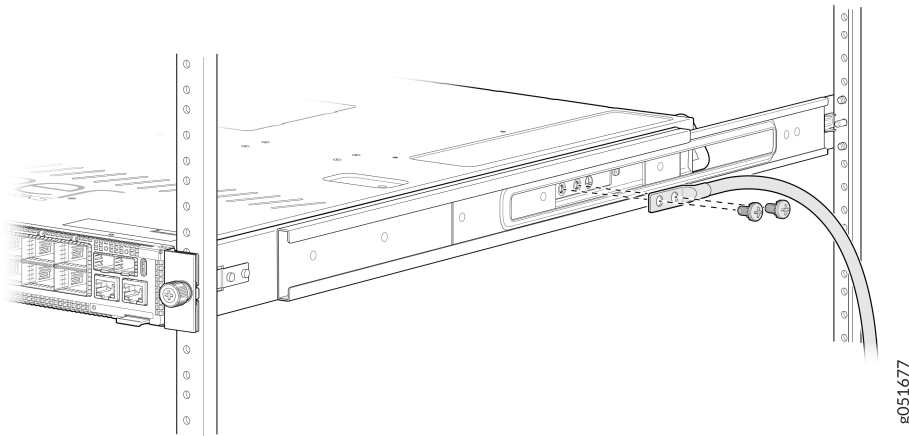

5. Connect the remaining end of the grounding cable to a proper earth ground, such as the rack in which the switch is mounted.
6. Dress the grounding cable to ensure safety.

**i** NOTE:

- The grounding cable must not touch other device components or obstruct access to the device.
- Arrange the cable such that it does not drape in areas where people could trip over it.

To gain additional grounding for the chassis of your QFX5241-32OD switch, connect the PSU in the switch into a grounded power outlet. Use a power cord appropriate for your geographical location.

## Connect AC Power to QFX5241-32OD Switch

Ensure that you have a power cord appropriate for your geographical location available to connect AC power to the switch.

Before you begin connecting AC power to the switch:

- Ensure that you have taken the necessary precautions to prevent electrostatic discharge (ESD) damage.
- Ensure that you have connected the switch chassis to earth ground. See ["Ground the QFX5241-32OD Switch" on page 81](#)



**CAUTION:** Before you connect power to the switch, a licensed electrician must attach a cable lug to the grounding cables that you supply. A cable with an incorrectly attached lug can damage the switch (for example, by causing a short circuit).

To meet safety and electromagnetic interference (EMI) requirements and to ensure proper operation, you must connect the chassis to earth ground before you connect it to power. For installations that require a separate grounding conductor to the chassis, use the protective earthing terminal on the switch chassis to connect to the earth ground. For instructions on connecting earth ground, see ["Ground the QFX5241-32OD Switch" on page 81](#). The switch gains additional grounding when you plug the PSU in the switch into a grounded power outlet by using the AC power cord appropriate for your geographical location.

- Install the power supply units (PSUs) in the chassis. For instructions on installing the PSU in the QFX5241-32OD switch, see ["Install a Power Supply Unit in QFX5241-32OD Switch" on page 97](#).

The QFX5241-32OD switch ships from the factory with two preinstalled AC PSUs. The PSUs offer 1+1 redundancy for the AC input voltage range of 200 V through 240 V (up to 2400 W). However, for the AC input voltage range of 100 V through 127 V (up to 1000 W), there is no redundancy support. The PSUs are hot-removable and hot-insertable field-replaceable units (FRUs). You can replace a PSU in the slots adjacent to the fan modules without powering off the switch or disrupting its operation.



**NOTE:** QFX5241-32OD AC switch operates only in nonredundant mode when the AC input voltage range is 100–127 V. Any PSU or input power failure causes a system

failure in nonredundant mode. Maintain a minimum system input above 200 V for full-load operation in redundant mode.



**NOTE:** Each PSU must be connected to a dedicated power source outlet.

To connect AC power to the QFX5241-32OD switch:

1. Wrap and fasten one end of the ESD grounding strap around your bare wrist, and connect the other end to a site ESD point.
2. Ensure that the PSUs are fully inserted in the chassis and the latches are secure.
3. Locate the power cords shipped with the switch; the cords have plugs appropriate for your geographical location. See ["AC Power Cord Specifications" on page 34](#).

For each PSU:

- a. Connect the AC power cord. Insert the power cord coupler firmly into the AC inlet on the PSU faceplate.

**Figure 48: Connect the AC Power Cord**

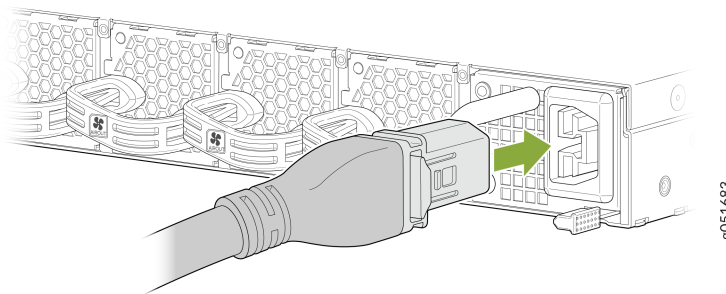

- b. Connect a dedicated customer-site two-pole circuit breaker for each PSU. We recommend that you use a dedicated customer-site circuit breaker rated for 20 A (250 V), or as required by local code.
4. If the AC power source outlet has a power switch, set it to the off (O) position.



**NOTE:** The switch powers on as soon as you provide power to the PSU. The device does not have a power switch.

5. Insert the power cord plug into an AC power source outlet.
6. If the AC power source outlet has a power switch, set it to the on (I) position.

7. Verify that the status LEDs on each PSU are lit green.

If the status LED is lit amber, disconnect the power cords from the PSU and replace the PSU. See ["Maintain the QFX5241-32OD Power System" on page 95](#).

Remove the PSU from the switch only when you have a replacement PSU ready. Install the PSUs in the switch to ensure proper airflow.

## Connect the QFX5241 Switch to External Devices

### IN THIS SECTION

- [Connect a Device to a Network for Out-of-Band Management | 85](#)
- [Connect a Device to a Management Console Using an RJ-45 Connector | 86](#)

### Connect a Device to a Network for Out-of-Band Management

Ensure that you have an Ethernet cable that has an RJ-45 connector at either end.

**Figure 49: RJ-45 Connector on an Ethernet Cable**

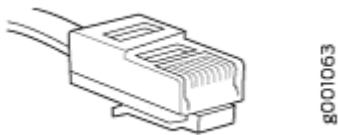

You can monitor and manage a network device, such as a router or a switch, by using a dedicated management channel. Each device has a management port to which you can connect an Ethernet cable with an RJ-45 connector. Use the management port to connect the device to the management device.

To connect a device to a network for out-of-band management:

1. Connect one end of the Ethernet cable to the management port on the device.
2. Connect the other end of the Ethernet cable to the management device.

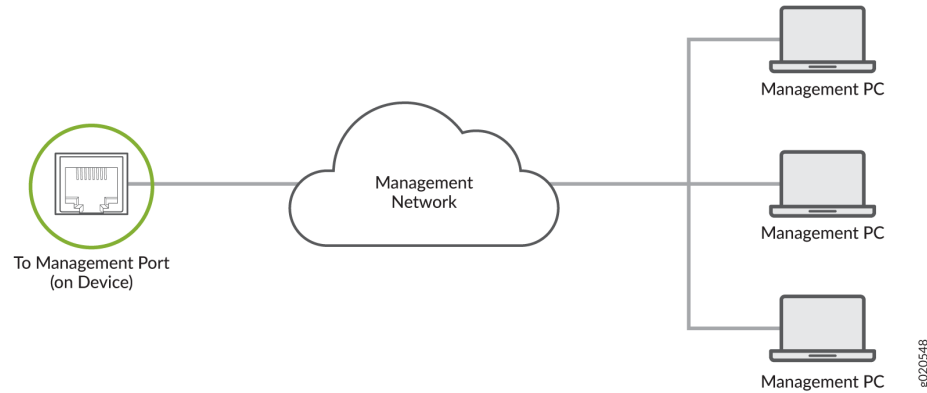

## Connect a Device to a Management Console Using an RJ-45 Connector

Ensure that you have an Ethernet cable that has an RJ-45 connector at either end and an RJ-45-to-DB-9 serial port adapter.

Figure 50: RJ-45 Connector on an Ethernet Cable

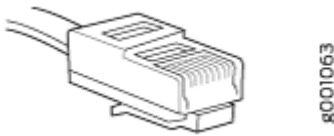

**NOTE:** We no longer include the RJ-45 console cable with the DB-9 adapter as part of the device package. If the console cable and adapter are not included in your device package, or if you need a different type of adapter, you can order the following separately:

- RJ-45 to DB-9 adapter (JNP-CBL-RJ45-DB9)
- RJ-45 to USB-A adapter (JNP-CBL-RJ45-USBA)
- RJ-45 to USB-C adapter (JNP-CBL-RJ45-USBC)

If you want to use RJ-45 to USB-A or RJ-45 to USB-C adapter, you must have X64 (64-Bit) Virtual COM port (VCP) driver installed on your PC. See <https://ftdichip.com/drivers/vcp-drivers/> to download the driver.



**NOTE:** If your laptop or desktop PC does not have a DB-9 plug connector pin and you want to connect your laptop or desktop PC directly to the device, use a combination of the RJ-45-to-DB-9 socket adapter and a USB-to-DB-9 plug adapter. You must provide the USB-to-DB-9 plug adapter.

You can configure and manage your network devices using a dedicated management channel. Each device has a console port that you can connect to using an Ethernet cable with an RJ-45 connector. Use the console port to connect the device to the console server or management console. The console port accepts a cable that has an RJ-45 connector.

To connect the device to a management console:

1. Connect one end of the Ethernet cable to the console port (labeled **CON**, **CONSOLE**, or **CON1**) on the device.
2. Connect the other end of the Ethernet cable to the console server (see [Figure 51 on page 87](#)) or management console (see [Figure 52 on page 87](#)).

**Figure 51: Connect a Device to a Management Console Through a Console Server**

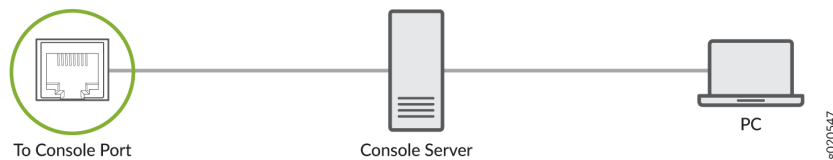

**Figure 52: Connect a Device Directly to a Management Console**



# Perform Initial Software Configuration for QFX5241-32OD Switch

Before you connect and configure the QFX5241-32OD switch, set the following parameter values on the console server or PC:

- Baud Rate—9600
- Flow Control—None
- Data—8
- Parity—None
- Stop Bits—1
- DCD State—Disregard

You must perform the initial configuration of the QFX5241-32OD switch through the console port using the CLI or through zero-touch provisioning (ZTP). In order to use ZTP to provision the device, you must have access to the following:

- Dynamic Host Control Protocol (DHCP) server—Provides the location of the software image and configuration files on the network.
- File Transfer Protocol (anonymous FTP), Hypertext Transfer Protocol (HTTP), Hypertext Transfer Protocol Secure (HTTPS), or Trivial File Transfer Protocol (TFTP) server—Stores the software image and configuration files.

For more information about using ZTP for provisioning the device, see [Understanding Zero Touch Provisioning](#) in the *Installation and Upgrade Guide*.

To connect and configure the switch from the console:

1. Connect the console port to a laptop or PC using an RJ-45 cable and an RJ-45-to-DB-9 adapter. The console (**CON**) port is located on the right side of the port panel, below the **MGMT** port.



**NOTE:** We no longer include the RJ-45 console cable with the DB-9 adapter as part of the device package. Check if any of the console cables and adapters are included in your device package. If you need a console cable or a different type of adapter, you can order the following separately:

- RJ-45 to DB-9 adapter (JNP-CBL-RJ45-DB9)
- RJ-45 to USB-A adapter (JNP-CBL-RJ45-USBA)
- RJ-45 to USB-C adapter (JNP-CBL-RJ45-USBC)

If you want to use RJ-45 to USB-A or RJ-45 to USB-C adapter, you must have X64 (64-Bit) Virtual COM port (VCP) driver installed on your PC. See, <https://ftdichip.com/drivers/vcp-drivers/> to download the driver.

2. Log in as **root**. You don't need to enter a password. If the software booted before you connected to the console port, you might need to press the **Enter** key for the prompt to appear.

```
login: root
```

3. Start the CLI.

```
root% cli
```

4. Enter configuration mode.

```
root> configure
```

5. Add a password to the root administration user account.

```
[edit]
root@# set system root-authentication plain-text-password
New password: password
Retype new password: password
```

6. (Optional) Configure the name of the switch. If the name includes spaces, enclose the name in quotation marks (" ").

```
[edit]
root@# set system host-name host-name
```

7. Configure the IP address and prefix length for the switch management interface.

```
[edit]
root@# set interfaces re0:mgmt-0 unit 0 family inet address address/prefix-length
```



**CAUTION:** Although the CLI allows you to configure two management Ethernet interfaces within the same subnet, only one interface is usable and supported.



**NOTE:** On the QFX5241-32OD switch, the management port `re0:mgmt-0` is the RJ-45 port on the top right side of the port panel and is labeled **MGMT**.

8. Create the `mgmt_junos` routing instance, and configure the static routes to remote prefixes with access to the management port.

```
[edit]
root@# set routing-instances mgmt_junos routing-options static route 0/0 next-hop
destination-ip
```

9. Enable the management instance.

```
[edit]
root@# set system management-instance
```

10. Enable the Telnet service.

```
[edit]
root@# set system services telnet
```



**NOTE:** When you enable Telnet, you cannot log in to QFX5241-32OD switch through Telnet using root credentials. Root login is allowed only for SSH access.

11. Enable SSH service for root login.

```
[edit]
root@# set system services ssh root-login allow
```

12. Commit the configuration to activate it on the switch.

```
[edit]
root@# commit
```

# 5

CHAPTER

## Maintain Components

---

### IN THIS CHAPTER

- Maintain the QFX5241-32OD Cooling System | **92**
  - Maintain the QFX5241-32OD Power System | **95**
  - Maintain the Solid-State Drive in a QFX5241-32OD Switch | **98**
  - Maintain Transceivers and Fiber Optic Cables on a QFX5241-32OD Switch | **102**
  - Power Off a QFX5241-32OD Switch | **111**
-

# Maintain the QFX5241-32OD Cooling System

## IN THIS SECTION

- [Remove a Fan Module from QFX5241-32OD Switch | 92](#)
- [Install a Fan Module in QFX5241-32OD Switch | 94](#)

The fan modules in the QFX5241-32OD switch are hot-removable and hot-insertable FRUs. You can remove and replace one of the fan modules without powering off the switch or disrupting switching function.

## Remove a Fan Module from QFX5241-32OD Switch

We ship the QFX5241-32OD switch from the factory with seven fan modules.

Before you remove a fan module from QFX5241-32OD switch, ensure that you have taken the necessary precautions to prevent electrostatic discharge (ESD) damage.



**CAUTION:** To ensure proper airflow, keep a failed fan module in place until you have a replacement fan module at hand. Do not run the device with an open fan tray slot for an extended amount of time.

Ensure that you have the following parts and tools available to remove the fan module from QFX5241-32OD switch:

- ESD grounding strap
- Antistatic bag or an antistatic mat
- Replacement fan module

Based on the ambient temperature, the time allowed to replace a fan module in the chassis varies.

**Table 29: Time Allowed to Replace a Fan Module**

Ambient Temperature (°C)	Duration
40	2 minutes

1. Place the antistatic bag or the antistatic mat on a flat, stable surface.
2. Wrap and fasten one end of the ESD grounding strap around your bare wrist, and connect the other end of the strap to the ESD point on the rack.
3. Grasp the handle on the fan module and squeeze the outside of the handle to release the module.

**Figure 53: Remove a Fan Module from QFX5241-32OD Switch**

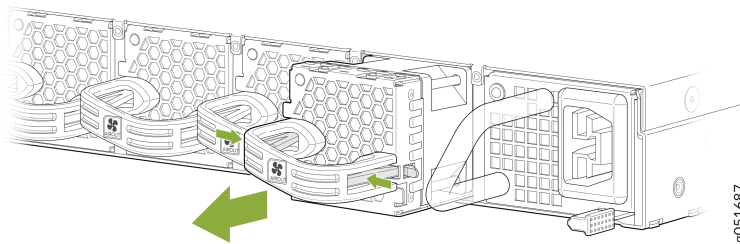

**WARNING:** To avoid injury, do not touch the fan with your hands or any tools as you slide the fan module out of the chassis—the fan might still be running.

4. Pull firmly to slide the fan module halfway out of the chassis.
5. When the fan stops spinning, use your other hand to support the fan module and slide the fan module completely out of the chassis.
6. Place the fan module in the antistatic bag or on the antistatic mat placed on a flat, stable surface.



**NOTE:** When you remove a fan module, the CLI message **Fan/Blower is Absent** is logged in the system log, and the system raises a major alarm.

## Install a Fan Module in QFX5241-32OD Switch

Before you install a fan module in QFX5241-32OD switch, ensure that you have taken the necessary precautions to prevent ESD damage.

The fan modules in the QFX5241-32OD switch are hot-removable and hot-insertable FRUs. You can remove and replace them without powering off the switch or disrupting switch functions.



**CAUTION:** To ensure proper airflow, keep a failed fan module in place until you have a replacement fan module at hand. Do not run the device with an open fan tray slot for an extended amount of time.



**NOTE:** For the QFX5241-32OD switch, the fan module provides AFO or front-to-back airflow.

To install a fan module in QFX5241-32OD switch:

1. Wrap and fasten one end of the ESD grounding strap around your bare wrist, and connect the other end of the strap to the ESD point on the rack.
2. Take care not to touch the connectors as you remove the fan module from its bag.
3. Align the module with the open slot and slide it in until it is fully seated.

**Figure 54: Install a Fan Module in a QFX5241-32OD Switch**

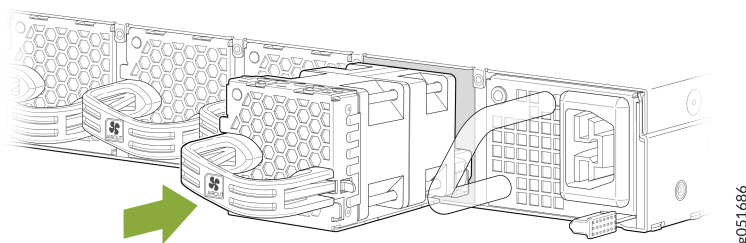

**CAUTION:** Damage can occur if you attempt to install a fan module into a chassis with a different airflow direction. Compare the switch product variant with the airflow marking on the handle to ensure that you are installing a fan module with the same airflow direction as the chassis. The fan modules are designed so that they can only be

inserted into the QFX5241-32OD product variant that supports the same airflow type. See "[Maintain the QFX5241-32OD Power System](#)" on page 95 for more information.

## Maintain the QFX5241-32OD Power System

### IN THIS SECTION

- [Remove a Power Supply Unit from QFX5241-32OD Switch | 95](#)
- [Install a Power Supply Unit in QFX5241-32OD Switch | 97](#)

QFX5241-32OD power supply units (PSUs) are hot-removable and hot-insertable FRUs. You can replace PSUs without powering off the switch or disrupting the switching function.

### Remove a Power Supply Unit from QFX5241-32OD Switch

We ship the AC variant of QFX5241-32OD switch from the factory with two power supply units (PSUs).

Before you remove a PSU from the QFX5241-32OD switch, ensure that you have taken the necessary precautions to prevent electrostatic discharge (ESD) damage.

Ensure that you have the following parts and tools available to remove a PSU from a QFX5241-32OD switch:

- ESD grounding strap
- Antistatic bag or an antistatic mat

To remove a PSU from the QFX5241-32OD switch:

1. Place the antistatic bag or the antistatic mat on a flat, stable surface.
2. Wrap and fasten one end of the ESD grounding strap around your bare wrist, and connect the other end of the strap to the ESD point on the rack.

**i** **NOTE:** If only one PSU is installed in your QFX5241-32OD switch, you need to power off the switch before removing the PSU. See ["Power Off a QFX5241-32OD Switch"](#) on page 111.

**3.** Disconnect power to the switch.

If the power source outlet has a power switch, set it to the off (O) position. If the power source outlet does not have a power switch, gently pull out the plug end of the power cord connected to the power source outlet.

**4.** Remove the power cord from the PSU faceplate.

AC PSU—Push the release tab on the AC power cord to detach it from the PSU faceplate. Then, gently pull out the socket end of the cord.

**Figure 55: Remove the AC PSU Power Cord**

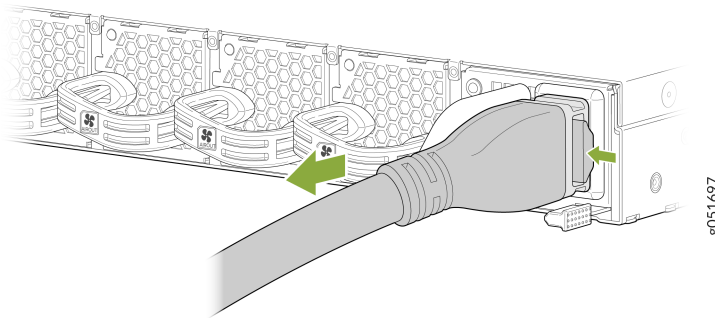

**5.** Press the PSU ejection lever from the side and hold.

**6.** Grasp the PSU handle and pull firmly to slide the PSU halfway out of the chassis.

**Figure 56: Remove an AC PSU from a QFX5241-32OD Switch**

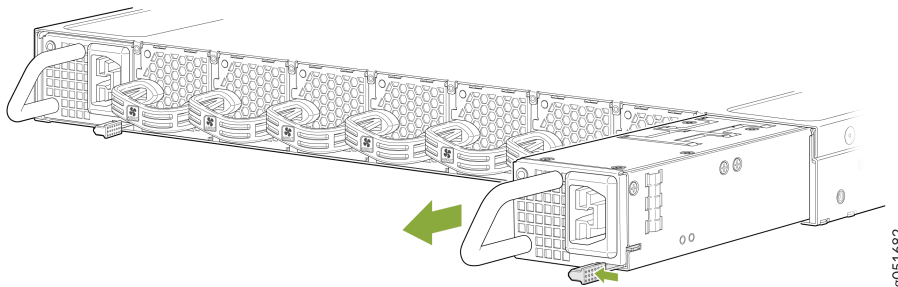

**7.** Place one hand under the PSU to support it and slide it completely out of the chassis. Take care not to touch the following:

- PSU components
  - Pins
  - Leads
  - Solder connections
8. Place the PSU in the antistatic bag or on the antistatic mat placed on a flat, stable surface.
  9. Replace the PSU with another PSU.

## Install a Power Supply Unit in QFX5241-32OD Switch

- Before you install a PSU in the QFX5241-32OD switch, ensure that you have taken the necessary precautions to prevent electrostatic discharge (ESD) damage.
- Ensure that the airflow direction of the PSU is the same as the chassis. Labels on the PSU handle indicate the direction of airflow. See "[QFX5241-32OD Cooling System](#)" on page 37 for more information.

To install a PSU in the QFX5241-32OD switch:

1. Wrap and fasten one end of the ESD grounding strap around your bare wrist, and connect the other end of the strap to the ESD point on the rack.
2. Remove the PSU from its bag, taking care not to touch the following:
  - PSU components
  - Pins
  - Leads
  - Solder connections



**CAUTION:** Verify that the direction of the arrow on the PSU handle matches the direction of airflow in the chassis. Ensure that each PSU you install in the chassis has the same airflow direction. If you install power supplies with two different airflow directions, Junos OS raises an alarm, and the status (**ALM**) LED blinks amber.

3. If the PSU has a protective plastic wrap, peel and remove the plastic wrap from all four sides of the PSU.
4. Using both hands, place the PSU in the PSU slot on the FRU panel of the switch and slide it in until it is fully seated.

Figure 57: Install an AC PSU in a QFX5241-32OD Switch

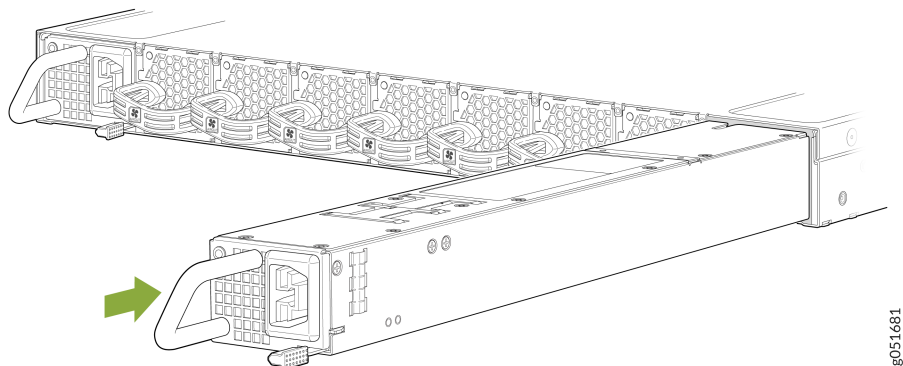

**NOTE:** Each PSU must be connected to a dedicated power source outlet.



**NOTE:** If you have a Juniper Care service contract, register any addition, change, or upgrade of hardware components at <https://www.juniper.net/customers/support/tools/updateinstallbase/>. Failure to do so can result in significant delays if you need replacement parts. This note does not apply if you replace existing components with the same type of component.

## Maintain the Solid-State Drive in a QFX5241-32OD Switch

### IN THIS SECTION

- [Remove the Solid-State Drive from a QFX5241-32OD Switch | 99](#)
- [Install the Solid-State Drive in a QFX5241-32OD Switch | 100](#)

The QFX5241-32OD switch supports two 480-GB SSDs. You cannot install or remove the SSDs when the switch is up. You must shut down the switch before replacing the SSD. The SSDs are preinstalled in the switch.

## Remove the Solid-State Drive from a QFX5241-32OD Switch

Before you remove a solid-state drive (SSD) from the device, ensure that you have taken the necessary precautions to prevent ESD damage.

Ensure that you have the following parts and tools available to remove an SSD from a QFX5241-32OD switch:

- ESD grounding strap
  - Antistatic bag or an antistatic mat
  - Phillips (+) screwdriver, number 1
1. Place the antistatic bag or the antistatic mat on a flat, stable surface.
  2. Wrap and fasten one end of the ESD grounding strap around your bare wrist, and connect the other end of the strap to the ESD point on the rack.
  3. Turn the switch chassis upside down and locate the SSD cover plate.
  4. Remove the three screws securing the SSD cover plate by using the Phillips (+) screwdriver.

**Figure 58: Remove the SSD Cover Plate**

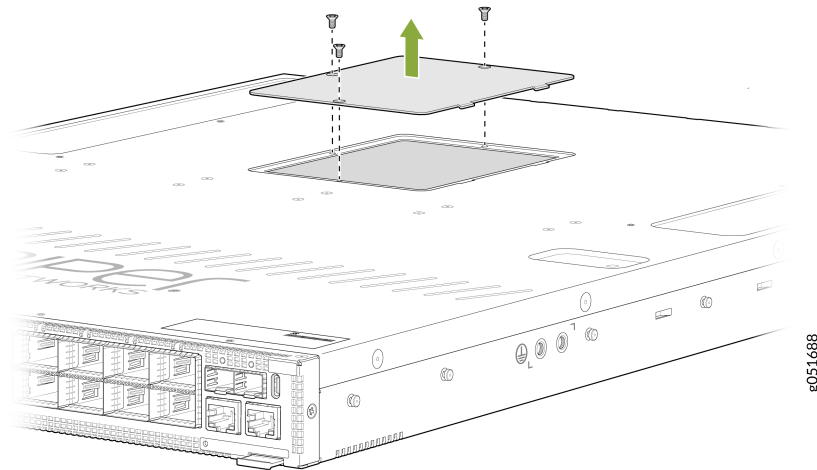

5. Remove the single screw holding the SSD in place and slide the drive out of its slot.

**Figure 59: Remove the SSDs**

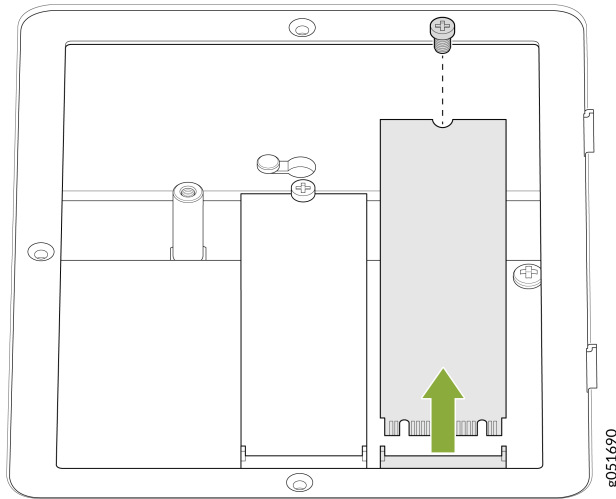

6. Place the SSD in an electrostatic bag or on an antistatic mat.
7. Place the SSD cover plate back on the chassis and tighten the three screws securing the SSD cover plate.

## Install the Solid-State Drive in a QFX5241-32OD Switch

Before you install an SSD in the device, ensure that you have taken the necessary precautions to prevent ESD damage.

Ensure that you have the following parts and tools available to install an SSD in the QFX5241-32OD switch:

- ESD grounding strap
  - Antistatic bag containing the SSD or an antistatic mat
  - Phillips (+) screwdriver, number 1
1. Place the antistatic bag or the antistatic mat on a flat, stable surface.
  2. Wrap and fasten one end of the ESD grounding strap around your bare wrist, and connect the other end of the strap to the ESD point on the rack.
  3. Turn the switch upside down and locate the SSD cover plate.
  4. If the screws are not already removed, remove the three screws securing the SSD cover plate by using the Phillips (+) screwdriver.

**Figure 60: Remove the SSD Cover Plate**

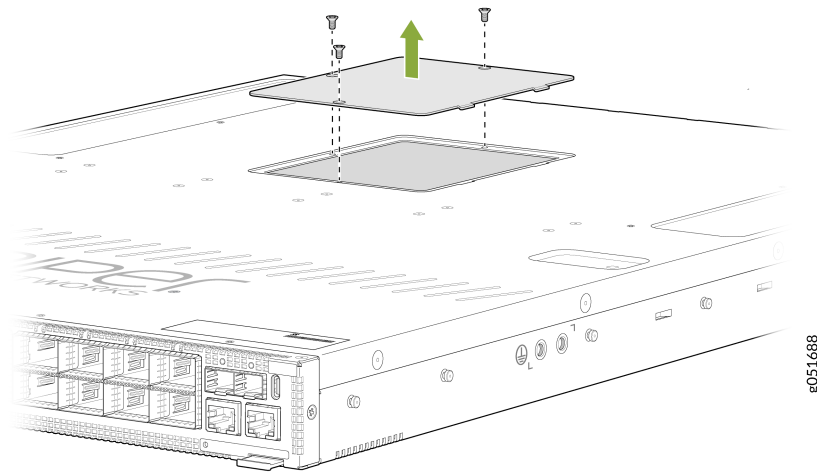

5. Slide the drive into the SSD slot and tighten the single screw holding the SSD.

**Figure 61: Install the SSD**

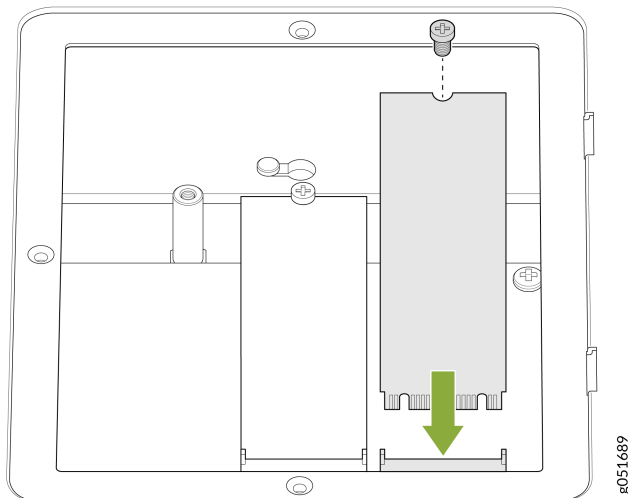

6. Place the SSD cover plate back on the chassis and tighten the three screws securing the SSD cover plate.

Figure 62: Replace the SSD Cover Plate

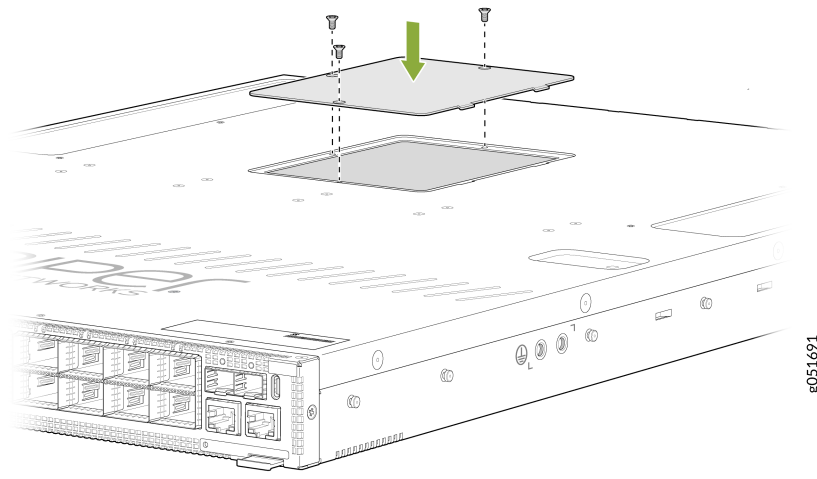

## Maintain Transceivers and Fiber Optic Cables on a QFX5241-32OD Switch

### IN THIS SECTION

- [Remove a Transceiver | 102](#)
- [Install a Transceiver | 105](#)
- [Disconnect a Fiber-Optic Cable | 107](#)
- [Connect a Fiber-Optic Cable | 108](#)
- [How to Handle Fiber-Optic Cables | 110](#)

### Remove a Transceiver

Use the information in this topic to remove octal small form factor pluggable (OSFP) optical transceivers and fiber-optic cables.



**CAUTION:** The Juniper Networks Technical Assistance Center (JTAC) provides complete support for Juniper-supplied optical modules and cables. However, JTAC does not provide support for third-party optical modules and cables that are not qualified or supplied by Juniper Networks. If you face a problem running a Juniper device that uses third-party optical modules or cables, JTAC may help you diagnose host-related issues if the observed issue is not, in the opinion of JTAC, related to the use of the third-party optical modules or cables. Your JTAC engineer will likely request that you check the third-party optical module or cable and, if required, replace it with an equivalent Juniper-qualified component.

Use of third-party optical modules with high-power consumption (for example, coherent ZR or ZR+) can potentially cause thermal damage to or reduce the lifespan of the host equipment. Any damage to the host equipment due to the use of third-party optical modules or cables is the users' responsibility. Juniper Networks will accept no liability for any damage caused due to such use.

Before you remove a transceiver from a device, ensure that you have taken the necessary precautions for the safe handling of lasers (see [Laser and LED Safety Guidelines and Warnings](#)).

Ensure that you have the following parts and tools available:

- An antistatic bag or an antistatic mat
- An electrostatic discharge (ESD) strap
- Rubber safety caps to cover the transceiver and fiber-optic cable connector
- A dust cover to cover the port or a replacement transceiver

The transceivers for Juniper Networks devices are hot-removable and hot-insertable field-replaceable units (FRUs). You can remove and replace the transceivers without powering off the device or disrupting device functions.



**NOTE:** After you remove a transceiver, or when you change the media-type configuration, wait for 6 seconds for the interface to display the operational commands.

To remove an OSFP transceiver:

1. Place the antistatic bag or antistatic mat on a flat, stable surface.
2. Wrap and fasten one end of the ESD wrist strap around your bare wrist, and connect the other end of the strap to the ESD point on the rack.
3. Label the cable connected to the transceiver so that you can reconnect it correctly.

**LASER WARNING:** Do not look directly into a fiber-optic transceiver or into the ends of fiber-optic cables. Fiber-optic transceivers and fiber-optic cables connected to transceivers emit laser light that can damage your eyes.

**LASER WARNING:** Do not leave a fiber-optic transceiver uncovered except when inserting or removing a cable. The rubber safety cap keeps the port clean and protects your eyes from accidental exposure to laser light.

**CAUTION:** Do not bend fiber-optic cables beyond their minimum bend radius. An arc smaller than a few inches in diameter can damage the cables and cause problems that are difficult to diagnose.

4. Remove the cable connected to the transceiver (see "[Disconnect a Fiber-Optic Cable](#)" on page 107). Cover the transceiver and the end of each fiber-optic cable connector with a rubber safety cap immediately after disconnecting the fiber-optic cables.
5. If there is a cable management system, arrange the cable in the cable management system to prevent it from dislodging or developing stress points. Secure the cable so that it does not support its own weight as it hangs to the floor. Place excess cable out of the way in a neatly coiled loop in the cable management system. Placing fasteners on the loop helps to maintain its shape.
6. Pull the transceiver's ejector tab straight back. The locking pins on the transceiver release automatically.
7. Gently slide the transceiver straight out of the port and place the transceiver on the antistatic mat or in the electrostatic bag.

**Figure 63: Remove an OSFP800 Transceiver**

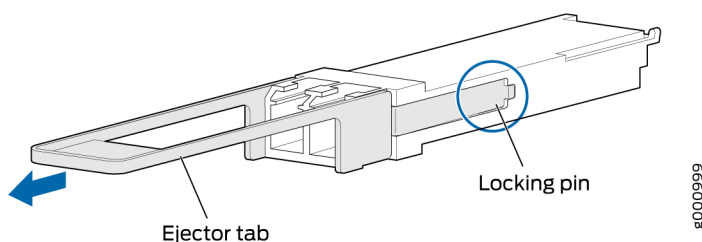

**CAUTION:** To avoid ESD damage to the transceiver, do not touch the connector pins at the end of the transceiver.



**NOTE:** After you remove a transceiver or after you change the media-type configuration, wait for 6 seconds for the interface to display operational commands.

8. Insert a dust cover in the empty port.

## Install a Transceiver

Use the information in this topic to install octal small form factor pluggable (OSFP) optical transceivers and fiber-optic cables.



**CAUTION:** The Juniper Networks Technical Assistance Center (JTAC) provides complete support for Juniper-supplied optical modules and cables. However, JTAC does not provide support for third-party optical modules and cables that are not qualified or supplied by Juniper Networks. If you face a problem running a Juniper device that uses third-party optical modules or cables, JTAC may help you diagnose host-related issues if the observed issue is not, in the opinion of JTAC, related to the use of the third-party optical modules or cables. Your JTAC engineer will likely request that you check the third-party optical module or cable and, if required, replace it with an equivalent Juniper-qualified component.

Use of third-party optical modules with high-power consumption (for example, coherent ZR or ZR+) can potentially cause thermal damage to or reduce the lifespan of the host equipment. Any damage to the host equipment due to the use of third-party optical modules or cables is the users' responsibility. Juniper Networks will accept no liability for any damage caused due to such use.

Before you install a transceiver in a device, ensure that you have taken the necessary precautions for safe handling of lasers (see [Laser and LED Safety Guidelines and Warnings](#)).

Ensure that you have a rubber safety cap available to cover the transceiver.

The transceivers for Juniper Networks devices are hot-removable and hot-insertable field-replaceable units (FRUs). You can remove and replace the transceivers without powering off the device or disrupting the device functions.



**NOTE:** After you insert a transceiver or after you change the media-type configuration, wait for 6 seconds for the interface to display operational commands.



**NOTE:** We recommend that you use only optical transceivers and optical connectors purchased from Juniper Networks with your Juniper Networks device.

To install an OSFP800 transceiver:

1. Wrap and fasten one end of the ESD wrist strap around your bare wrist, and connect the other end of the strap to a site ESD point or to the ESD point on the device.
2. Remove the transceiver from its bag.



**CAUTION:** To prevent electrostatic discharge (ESD) damage to the transceiver, do not touch the connector pins at the end of the transceiver.

3. Check to see whether the transceiver is covered with a rubber safety cap. If it is not, cover the transceiver with a rubber safety cap.



**LASER WARNING:** Do not leave a fiber-optic transceiver uncovered except when inserting or removing a cable. The rubber safety cap keeps the port clean and protects your eyes from accidental exposure to laser light.

4. If the port in which you want to install the transceiver is covered with a dust cover, remove the dust cover and save it in case you need to cover the port later. If you are hot-swapping a transceiver, wait for at least 10 seconds after removing the transceiver from the port before installing a new transceiver.



**NOTE:** Make sure to use a dust cap to cover ports that are unused.

5. Orient the transceiver over the port so that the transceiver connector faces the appropriate direction.
6. Slide the transceiver into the slot until the locking pins lock in place. If there is resistance, remove the transceiver and flip it so that the connector faces the other direction.

Figure 64: Install an OSFP800 Transceiver

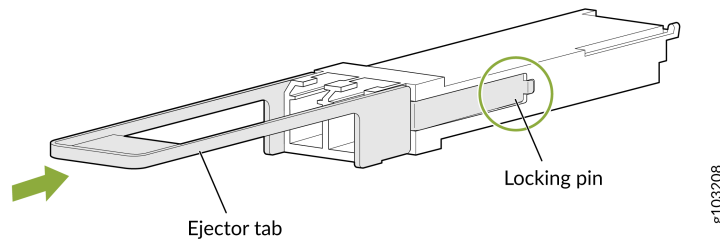

7. Remove the rubber safety cap from the transceiver when you are ready to connect the cable to the transceiver.

**LASER WARNING:** Do not look directly into a fiber-optic transceiver or into the ends of fiber-optic cables. Fiber-optic transceivers and fiber-optic cables connected to transceivers emit laser light that can damage your eyes.

8. If there is a cable management system, arrange the cable in the cable management system to prevent the cable from dislodging or developing stress points. Secure the cable so that it does not support its own weight as it hangs toward the floor. Place excess cable out of the way in a neatly coiled loop in the cable management system. Placing fasteners on the loop helps to maintain its shape.

**CAUTION:** Do not let fiber-optic cable hang free from the connector. Do not allow fastened loops of cable to dangle, which stresses the cable at the fastening point.

**CAUTION:** Avoid bending the fiber-optic cable beyond its minimum bend radius. An arc smaller than a few inches in diameter can damage the cable and cause problems that are difficult to diagnose.

## Disconnect a Fiber-Optic Cable

Before you disconnect a fiber-optic cable from an optical transceiver, ensure that you have taken the necessary precautions for safe handling of lasers. See [Laser and LED Safety Guidelines and Warnings](#).

Ensure that you have the following parts and tools available:

- Electrostatic discharge (ESD) strap
- A rubber safety cap to cover the transceiver

- A rubber safety cap to cover the fiber-optic cable connector

Juniper Networks devices have optical transceivers to which you can connect fiber-optic cables.

To disconnect a fiber-optic cable from an optical transceiver installed in the device:

1. Disable the port in which the transceiver is installed by issuing the following command:

```
[edit interfaces]
user@device# set interface-name disable
```



**LASER WARNING:** Do not look directly into a fiber-optic transceiver or into the ends of fiber-optic cables. Fiber-optic transceivers and fiber-optic cables connected to transceivers emit laser light that can damage your eyes.

2. Carefully unplug the fiber-optic cable connector from the transceiver.
3. Cover the transceiver with a rubber safety cap.



**LASER WARNING:** Do not leave a fiber-optic transceiver uncovered except when inserting or removing a cable. The rubber safety cap keeps the port clean and protects your eyes from accidental exposure to laser light.

4. Cover the fiber-optic cable connector with the rubber safety cap.

## Connect a Fiber-Optic Cable

Before you connect a fiber-optic cable to an optical transceiver installed in a device, ensure that you have taken the necessary precautions for safe handling of lasers (see [Laser and LED Safety Guidelines and Warnings](#)).

To connect a fiber-optic cable to an optical transceiver installed in a device:



**LASER WARNING:** Do not look directly into a fiber-optic transceiver or into the ends of fiber-optic cables. Fiber-optic transceivers and fiber-optic cables connected to transceivers emit laser light that can damage your eyes.

1. To enable the disabled port, delete the disable statement from the configuration and commit the configuration changes:

```
{master}[edit interfaces]
root@re0# show
et-0/0/1 {
    disable;
}

{master}[edit interfaces]
root@re0# delete et-0/0/1 disable

{master}[edit interfaces]
root@re0# show

{master}[edit interfaces]
root@re0# show |compare
[edit interfaces]
- et-0/0/1 {
-     disable;
- }

{master}[edit interfaces]
root@re0# commit
commit complete

{master}[edit]
root@re0#
```

2. If the fiber-optic cable connector is covered with a rubber safety cap, remove the cap. Save the cap.
3. Remove the rubber safety cap from the optical transceiver. Save the cap.
4. Insert the cable connector into the optical transceiver.

**Figure 65: Connect a Fiber-Optic Cable to an Optical Transceiver Installed in a Device**

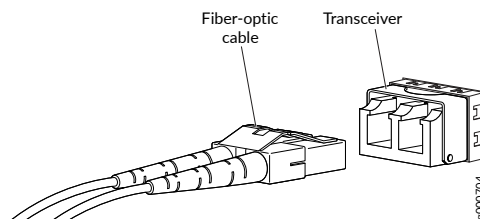

5. Secure the cables so that they do not support their own weight. Place excess cable out of the way in a neatly coiled loop. Placing fasteners on a loop helps cables maintain their shape.



**CAUTION:** Do not bend fiber-optic cables beyond their minimum bend radius. An arc smaller than a few inches in diameter can damage the cables and cause problems that are difficult to diagnose.

Do not let fiber-optic cables hang free from the connector. Do not allow fastened loops of cables to dangle, which stresses the cables at the fastening point.

## How to Handle Fiber-Optic Cables

Fiber-optic cables connect to optical transceivers that are installed in Juniper Networks devices.

Follow these guidelines when handling fiber-optic cables:

- When you unplug a fiber-optic cable from a transceiver, place rubber safety caps over the transceiver and on the end of the cable.
- Anchor fiber-optic cables to prevent stress on the connectors. When attaching a fiber-optic cable to a transceiver, secure the fiber-optic cable so that it does not support its own weight as it hangs to the floor. Never let a fiber-optic cable hang free from the connector.
- Avoid bending the fiber-optic cables beyond their minimum bend radius. Bending fiber-optic cables into arcs smaller than a few inches in diameter can damage the cables and cause problems that are difficult to diagnose.
- Frequent plugging and unplugging of fiber-optic cables in and out of optical instruments can damage the instruments, which are expensive to repair. To prevent damage from overuse, attach a short fiber extension to the optical equipment. The short fiber extension absorbs wear and tear due to frequent plugging and unplugging. It is easier and more cost-efficient to replace the short fiber extension than to replace the instruments.
- Keep fiber-optic cable connections clean. Microdeposits of oil and dust in the canal of the transceiver or cable connector can cause loss of light, reduction in signal power, and possibly intermittent problems with the optical connection.
  - To clean the transceiver canal, use an appropriate fiber-cleaning device such as RIFOCS Fiber Optic Adaptor Cleaning Wands (part number 946). Follow the instructions in the cleaning kit you use.

- After cleaning the transceiver, make sure that the connector tip of the fiber-optic cable is clean. Use only an approved alcohol-free fiber-optic cable cleaning kit such as the Opptex Cletop-S® Fiber Cleaner. Follow the instructions in the cleaning kit you use.

## Power Off a QFX5241-32OD Switch

Before you remove the power cord to power off a QFX5241-32OD switch:

- Ensure that you have taken the necessary precautions to prevent electrostatic discharge (ESD) damage. See [Prevention of Electrostatic Discharge Damage](#).
- Ensure that you do not need to forward traffic through the switch.

Ensure that you have the following parts and tools available to power off the switch:

- An ESD grounding strap
- An external management device such as a PC
- An RJ-45-to-DB-9 rollover cable to connect the external management device to the console port

To power off a QFX5241-32OD switch:

1. Connect to the switch using one of the following methods:

- Connect a management device to the console (**CON**) port on the QFX5241-32OD switch. For instructions about connecting a management device to the console (**CON**) port, see "[Connect a Device to a Management Console Using an RJ-45 Connector](#)" on page 86.
- Shut down the QFX5241-32OD switch from a management device on your out-of-band management network. For instructions about connecting a management device to the management (**MGMT**) port, see "[Connect a Device to a Network for Out-of-Band Management](#)" on page 85.

2. Shut down Junos OS Evolved from the external management device.

For a QFX5241-32OD switch, issue the request `system shutdown power-off` operational mode CLI command. This command shuts down the switch gracefully and preserves system state information. A message appears on the console, confirming that the operating system has halted. You can see the following output:

```
user@host>request system shutdown power-off
Power off the system ? [yes,no] (n) yes
*** System shutdown message from user@host
```

```
poweroff the system at Thu Jul 10 11:29:25 2025
```

```
user@host>
```

```
System going down IMMEDIATELY
```



**CAUTION:** Wait at least 60 seconds after first seeing the final message before following the instructions in Step 4 and Step 5 to power off the switch.

3. Wrap and fasten one end of the ESD wrist strap around your bare wrist, and connect the other end of the strap to a site ESD point or to the ESD point on the device.
4. Disconnect AC power to the switch by performing one of the following tasks:
  - If the AC power source outlet has a power switch, set it to the off (O) position.
  - If the AC power source outlet does not have a power switch, gently pull out the plug end of the power cord connected to the power source outlet.
5. Remove the AC power source cable from the power supply faceplate:
  - Remove the AC power cord from the power supply faceplate by detaching the power cord retainer and gently pulling out the socket end of the power cord connected to the power supply faceplate.
6. Uncable the switch before removing it from the rack.

# 6

CHAPTER

## Troubleshoot Hardware

---

### IN THIS CHAPTER

- [Troubleshoot the QFX5241-32OD Switch | 114](#)
-

# Troubleshoot the QFX5241-32OD Switch

## IN THIS SECTION

- [QFX5241-32OD Troubleshooting Resources Overview | 114](#)
- [QFX5241-32OD Alarm Messages Overview | 115](#)
- [Chassis Alarm Messages | 117](#)

## QFX5241-32OD Troubleshooting Resources Overview

To troubleshoot a problem on the QFX5241-32OD switch, you can use:

- Junos Evolved OS CLI

The CLI is the primary tool for controlling and troubleshooting hardware, Junos OS Evolved, routing protocols, and network connectivity. CLI commands display information from routing tables, information specific to routing protocols, and information about network connectivity derived from the ping and traceroute utilities. For information about using the CLI to troubleshoot Junos OS Evolved, see the appropriate Junos OS Evolved configuration guide.

- Alarms and LEDs on the network ports, management panel, and components

When the Routing Engine detects an alarm condition, it lights the red or yellow alarm LED on the management panel as appropriate. In addition, you can also use FRU LEDs and network port LEDs to troubleshoot the QFX5241-32OD switch. For more information, see "[QFX5241-32OD Switch Management Panel](#)" on page 24.

- JTAC

If you need assistance during troubleshooting, you can contact the Juniper Networks Technical Assistance Center (JTAC) by using the Web or by telephone. If you encounter software problems, or problems with hardware components not discussed here, contact JTAC.

- Knowledge Base articles—[Knowledge Base](#).

## QFX5241-32OD Alarm Messages Overview

When the QFX5241-32OD switch detects an alarm condition, it lights the red or yellow alarm LED on the management panel as appropriate. To view a more detailed description of the alarm cause, issue the `show system alarms operational` CLI command.

```
user@host> show system alarms
0 alarms currently active
```

For thermal problems, the `show chassis temperature-thresholds` CLI command shows the cutoff temperatures for each level of alarm:

```
user@host> show chassis temperature-thresholds
```

Item	Fan speed		Yellow alarm		Red alarm		Fire
	(degrees C)	(degrees C)	(degrees C)	(degrees C)	(degrees C)	(degrees C)	(degrees C)
Item	Normal	High	Normal	Bad fan	Normal	Bad fan	Normal
Shutdown							
(degrees C)							
Routing Engine 0 CPU Temperature	70	80	92	89	96	93	98
Routing Engine 0 Ch-0 DIMM-0 Temp	63	70	82	79	85	82	88
Routing Engine 0 Ch-1 DIMM-0 Temp	63	70	82	79	85	82	88
FPC 0 Sensor TH5 Max Reading	75	85	102	99	105	102	110
FPC 0 xcvr-0/0/0	53	60	73	73	76	76	77
FPC 0 xcvr-0/0/1	53	60	73	73	76	76	77
FPC 0 xcvr-0/0/2	53	60	73	73	76	76	77
FPC 0 xcvr-0/0/3	53	60	73	73	76	76	77
FPC 0 xcvr-0/0/4	53	60	73	73	76	76	77
FPC 0 xcvr-0/0/5	53	60	73	73	76	76	77
FPC 0 xcvr-0/0/6	53	60	73	73	76	76	77
FPC 0 xcvr-0/0/7	53	60	73	73	76	76	77
FPC 0 xcvr-0/0/8	53	60	73	73	76	76	77
FPC 0 xcvr-0/0/9	53	60	73	73	76	76	77
FPC 0 xcvr-0/0/10	53	60	73	73	76	76	77
FPC 0 xcvr-0/0/11	53	60	73	73	76	76	77
FPC 0 xcvr-0/0/12	53	60	73	73	76	76	77
FPC 0 xcvr-0/0/13	53	60	73	73	76	76	77
FPC 0 xcvr-0/0/14	53	60	73	73	76	76	77
FPC 0 xcvr-0/0/15	53	60	73	73	76	76	77
FPC 0 xcvr-0/0/16	53	60	73	73	76	76	77
FPC 0 xcvr-0/0/17	53	60	73	73	76	76	77
FPC 0 xcvr-0/0/18	53	60	73	73	76	76	77

```

FPC 0 xcvr-0/0/19          53  60  73  73  76  76  77
FPC 0 xcvr-0/0/20          53  60  73  73  76  76  77
FPC 0 xcvr-0/0/21          53  60  73  73  76  76  77
FPC 0 xcvr-0/0/22          53  60  73  73  76  76  77
FPC 0 xcvr-0/0/23          53  60  73  73  76  76  77
FPC 0 xcvr-0/0/24          53  60  73  73  76  76  77
FPC 0 xcvr-0/0/25          53  60  73  73  76  76  77
FPC 0 xcvr-0/0/26          53  60  73  73  76  76  77
FPC 0 xcvr-0/0/27          53  60  73  73  76  76  77
FPC 0 xcvr-0/0/28          53  60  73  73  76  76  77
FPC 0 xcvr-0/0/29          53  60  73  73  76  76  77
FPC 0 xcvr-0/0/30          53  60  73  73  76  76  77
FPC 0 xcvr-0/0/31          53  60  73  73  76  76  77
FPC 0 xcvr-0/0/32          50  57  70  70  75  75  76
FPC 0 xcvr-0/0/33          50  57  70  70  75  75  76
FPC 0 MB Right Rear        60  65  80  77  85  82  90
FPC 0 MB Middle Rear       65  70  85  82  90  87  95
FPC 0 MB Left Rear         60  65  80  77  85  82  90
FPC 0 MB Left Front        55  60  80  77  85  82  90
FPC 0 System Inlet         25  30  50  47  53  50  55
FPC 0 MB Right Front       45  50  80  77  85  82  90
FPC 0 MB OPTICS_GRP1_3V3   75  80  115  112  120  117  125
FPC 0 MB OPTICS_GRP3_3V3   75  80  115  112  120  117  125
FPC 0 MB VDD_0P75          75  80  115  112  120  117  125
FPC 0 MB TRVDD1_0V9_0V75   75  80  115  112  120  117  125
FPC 0 MB TRVDD0_0V9_0V75   75  80  115  112  120  117  125
FPC 0 FB Exhaust Right     53  60  73  70  75  72  77
FPC 0 FB Exhaust Left      48  55  67  64  70  67  75
user@host>

```

You can also calculate the percentage of fan RPM, or *duty cycle*. Use the following command to know the fan RPM percentage:

```
root@re0> show chassis fan
```

Item	Status	% RPM	Measurement
Fan Tray 0 Fan 1	OK	57%	18150 RPM
Fan Tray 0 Fan 2	OK	57%	16500 RPM
Fan Tray 1 Fan 1	OK	58%	18450 RPM
Fan Tray 1 Fan 2	OK	57%	16500 RPM
Fan Tray 2 Fan 1	OK	58%	18300 RPM
Fan Tray 2 Fan 2	OK	58%	16650 RPM

```

Fan Tray 3 Fan 1      OK      58%      18300 RPM
Fan Tray 3 Fan 2      OK      57%      16350 RPM
Fan Tray 4 Fan 1      OK      57%      18150 RPM
Fan Tray 4 Fan 2      OK      57%      16350 RPM
Fan Tray 5 Fan 1      OK      57%      18150 RPM
Fan Tray 5 Fan 2      OK      57%      16500 RPM
Fan Tray 6 Fan 1      OK      58%      18300 RPM
Fan Tray 6 Fan 2      OK      58%      16650 RPM
root@re0>

```

## Chassis Alarm Messages

Chassis alarms indicate a failure on the device or one of its components. Chassis alarms are preset and cannot be modified.

Chassis alarms on the QFX5241-32OD switch has two severity levels:

- Major (red)—Indicates a critical situation on the device that has resulted from one of the conditions described in [Table 30 on page 117](#). A red alarm condition requires immediate action.
- Minor (yellow)—Indicates a noncritical condition on the device that, if left unchecked, might cause an interruption in service or degradation in performance. A yellow alarm condition requires monitoring or maintenance.

Junos OS Evolved systems, such as the QFX5241-32OD switch, are based on a new alarm infrastructure, which does not support all PSUs and fan alarms. [Table 30 on page 117](#) shows these alarms, the alarm messages, and the recommended action to take.

**Table 30: Chassis Alarm Messages for QFX5241-32OD Switch**

Component	Alarm Type	CLI Message	Recommended Action
Fans	Red (major)	Fan Tray <i>fan-tray-number</i> Absent	Install fan modules in the slots where they are absent.
		Fan Tray <i>fan-tray-number</i> Failure	Remove and check the fan module for obstructions. Reinsert the fan module. If the problem persists, replace the fan module.

Table 30: Chassis Alarm Messages for QFX5241-32OD Switch (Continued)

Component	Alarm Type	CLI Message	Recommended Action
		<i>sensor-location</i> Temp Sensor Too Hot	Check the environmental conditions and alarms on other devices. Ensure that environmental factors (such as hot air blowing around the equipment) do not affect the temperature sensor. If the condition persists, the device might shut down.
	Yellow (minor)	FAN <i>fan-number</i> Fan Sensor Fail	Remove and check the fan module for obstructions. Reinsert the fan module. If the problem persists, check the system log for the message related to the sensor and report the message to customer service.
		<i>sensor-location</i> Temp Sensor Too Warm	Check the environmental conditions and alarms on other devices. Ensure that environmental factors (such as hot air blowing around the equipment) do not affect the temperature sensor.
PSUs	Red (major)	PEM <i>pem-number</i> Not Powered	Install a PSU into the empty slot. Ensure that the PSU is receiving power.
Temperature sensors	Major (red)	FPC $\emptyset$ Temperature Hot	Check environmental conditions and alarms on other devices. Ensure that environmental factors (such as hot air blowing around the equipment) do not affect the temperature sensor. If the condition persists, the device might shut down.

Table 30: Chassis Alarm Messages for QFX5241-32OD Switch (Continued)

Component	Alarm Type	CLI Message	Recommended Action
	Minor (yellow)	FPC 0 Temperature Warm	Check environmental conditions and alarms on other devices. Ensure that environmental factors (such as hot air blowing around the equipment) do not affect the temperature sensor.
		FPC 0 Temp Sensor Fail	Check the system log for an error message. Report the message to customer support.
Routing Engine	Major (red)	RE <i>RE number</i> /var partition is full	File storage is at capacity. Reduce unnecessary files to free space.
	Minor (yellow)	RE <i>RE number</i> /var partition is high	File storage is reaching capacity. Reduce unnecessary files to free space.
Management Ethernet interface	Major (red)	Management interface <i>management-interface-name</i> down on <i>node</i>	Check whether a cable is connected to the management Ethernet interface, or whether the cable is defective. Replace the cable, if required.

# 7

CHAPTER

## Contacting Customer Support and Returning the Chassis or Components

---

### IN THIS CHAPTER

- [Return QFX5241-32OD Chassis or Components | 121](#)
-

# Return QFX5241-32OD Chassis or Components

## IN THIS SECTION

- [Return a QFX541-32OD Switch or Component for Repair or Replacement | 121](#)
- [Contact Customer Support to Obtain a Return Material Authorization | 122](#)
- [Locate the Serial Number on QFX5241-32OD Devices or Components | 123](#)
- [Remove the Solid-State Drives for RMA on a QFX5241-32OD Switch | 126](#)
- [How to Return a Hardware Component to Juniper Networks, Inc. | 129](#)
- [Guidelines for Packing Hardware Components for Shipment | 129](#)
- [Pack QFX5241-32OD Switch or Component for Shipping | 130](#)

## Return a QFX541-32OD Switch or Component for Repair or Replacement

Use this procedure to return QFX541-32OD hardware to Juniper Networks for repair or replacement:

1. Determine the serial number of the chassis if you need to return the switch. If you need to return one or more components, determine the serial number for each component. For instructions, see "[Locate the Serial Number on QFX5241-32OD Devices or Components](#)" on page 123.
2. Obtain a Return Material Authorization (RMA) number from Juniper Networks Technical Assistance Center (JTAC) as described in "[Contact Customer Support to Obtain a Return Material Authorization](#)" on page 122.
3. Pack the switch or component for shipping.



**NOTE:** For more information about return and repair policies, see the customer support page at <https://support.juniper.net/support/guidelines/>.

## Contact Customer Support to Obtain a Return Material Authorization

If you need to return a device or hardware component to Juniper Networks for repair or replacement, obtain an RMA number from JTAC. You must obtain an RMA number before you attempt to return the component.

After locating the serial number of the device or hardware component you want to return, open a service request with the JTAC on the Web or by telephone.

Before you request an RMA number from JTAC, be prepared to provide the following information:

- Your existing service request number, if you have one
- Serial number of the component
- Your name, organization name, telephone number, fax number, and shipping address
- Details of the failure or problem
- Type of activity being performed on the device when the problem occurred
- Configuration data displayed by one or more `show` commands

You can contact JTAC 24 hours a day, seven days a week, on the Web or by telephone:

- Service Request Manager: <https://support.juniper.net/support>
- Telephone: +1-888-314-JTAC (+1-888-314-5822), toll free in U.S., Canada, and Mexico



**NOTE:** For international or direct-dial options in countries without toll free numbers, see <https://support.juniper.net/support>.

If you are contacting JTAC by telephone, enter your 12-digit service request number followed by the pound (#) key for an existing case, or press the star (\*) key to be routed to the next available support engineer.

The support representative validates your request and issues an RMA number for return of the component.

## Locate the Serial Number on QFX5241-32OD Devices or Components

### IN THIS SECTION

- [List the Chassis and Component Details with the CLI | 123](#)
- [Locate the Chassis Serial Number ID Label on QFX5241-32OD Switch | 125](#)
- [Locate the Serial Number ID Labels on FRUs in a QFX5241-32OD Switch | 125](#)

If you need to return a switch or component to Juniper Networks for repair or replacement, you must locate the serial number of the switch or component. You must provide this serial number to the Juniper Networks Technical Assistance Center (JTAC) when you contact them to obtain a Return Materials Authorization (RMA).

If the switch is operational and you can access the CLI, you can list serial numbers for the switch and for some components with a CLI command. If you do not have access to the CLI or if the serial number for the component does not appear in the command output, you can locate the serial number ID label on the switch or component.



**NOTE:** If you want to find the serial number ID label on a component, you need to remove the component from the switch chassis, for which you must have the required parts and tools available.

### List the Chassis and Component Details with the CLI

To list the switch and components and their serial numbers, enter the following CLI command:

```
show chassis hardware
```

The following output lists the switch components and serial numbers for a QFX5241-32OD switch. The output is similar for other QFX5241-32OD switches:

```
user@device> show chassis hardware
Hardware inventory:
Item          Version  Part number  Serial number  Description
Chassis              HV1925AX0004  QFX5241-320D
PSM 0              REV 02   640-184862  1EXXF140013  AC AFO 2400W PSU
PSM 1              REV 02   640-184862  1EXXF14001E  AC AFO 2400W PSU
Routing Engine 0    BUILTIN  BUILTIN      RE-QFX5241
CB 0               REV 06   650-184058  HV1925AX0004  QFX5241-320D
```

FPC 0		BUILTIN	BUILTIN	QFX5241-320D
PIC 0		BUILTIN	BUILTIN	32X800G-OSFPDD
Xcvr 0	REV 01	740-174933	1W1CVWA90100N	OSFP-800G-DR8
Xcvr 1	REV 01	740-174933	XA9BQ3D	OSFP-800G-DR8
Xcvr 2	REV 01	740-174933	1W1CVWA90100S	OSFP-800G-DR8
Xcvr 3	REV 01	740-174940	1F1THVA951001	OSFP-800G-DR8-2-P
Xcvr 4	REV 01	740-174940	1F1THVA95101B	OSFP-800G-DR8-2-P
Xcvr 5	REV 01	740-174933	XA8AKWV	OSFP-800G-DR8
Xcvr 6	REV 01	740-174933	XA8AKTL	OSFP-800G-DR8
Xcvr 7	REV 01	740-174933	1W1CVWA84301V	OSFP-800G-DR8
Xcvr 8	REV 01	740-174933	1W1CVWA84301X	OSFP-800G-DR8
Xcvr 9	REV 01	740-174933	XA8AKW4	OSFP-800G-DR8
Xcvr 10	REV 01	740-174933	XA8AKX7	OSFP-800G-DR8
Xcvr 11	REV 01	740-174933	XA8AKRD	OSFP-800G-DR8
Xcvr 12	REV 01	740-174933	XA8AKRA	OSFP-800G-DR8
Xcvr 13	REV 01	740-174942	1W1CHAA935003	OSFP-800G-AOC-1M
Xcvr 14	REV 01	740-174942	1W1CHAA935003	OSFP-800G-AOC-1M
Xcvr 15	REV 01	740-174942	1A1CHAA944T0G	OSFP-800G-AOC-1M
Xcvr 16	REV 01	740-174942	1A1CHAA944T0G	OSFP-800G-AOC-1M
Xcvr 17	REV 01	740-174948	1W1CHGA935003	OSFP-800G-AOC-20M
Xcvr 18	REV 01	740-174948	1W1CHGA935003	OSFP-800G-AOC-20M
Xcvr 19	REV 01	740-183989	1W1CJAAA0200F	OSFP-800G-DR8-LPO
Xcvr 20	REV 01	740-183989	1W1CJAAA0200D	OSFP-800G-DR8-LPO
Xcvr 21	REV 01	740-174942	1W1CHAA935002	OSFP-800G-AOC-1M
Xcvr 22	REV 01	740-174942	1W1CHAA935002	OSFP-800G-AOC-1M
Xcvr 23	REV 01	740-183989	1W1CJAAA0200E	OSFP-800G-DR8-LPO
Xcvr 24	REV 01	740-183989	1W1CJAAA0200C	OSFP-800G-DR8-LPO
Xcvr 25	REV 01	740-174933	1W1CVWA90100E	OSFP-800G-DR8
Xcvr 26	REV 01	740-174933	1W1CVWA84301W	OSFP-800G-DR8
Xcvr 27	REV 01	740-174940	1F1THVA95101H	OSFP-800G-DR8-2-P
Xcvr 28	REV 01	740-174940	1F1THVA951017	OSFP-800G-DR8-2-P
Xcvr 29	REV 01	740-174933	1W1CVWA90100T	OSFP-800G-DR8
Xcvr 30	REV 01	740-174933	1W1CVWA90100Q	OSFP-800G-DR8
Xcvr 31	REV 01	740-174933	XA8AKXJ	OSFP-800G-DR8
Xcvr 32	REV 01	740-021308	NAJD00Z	SFP+-10G-SR
Xcvr 33	REV 01	740-021308	NAJCY4W	SFP+-10G-SR
Fan Tray 0				Fan Tray, Front to Back Airflow - AFO
Fan Tray 1				Fan Tray, Front to Back Airflow - AFO
Fan Tray 2				Fan Tray, Front to Back Airflow - AFO
Fan Tray 3				Fan Tray, Front to Back Airflow - AFO
Fan Tray 4				Fan Tray, Front to Back Airflow - AFO
Fan Tray 5				Fan Tray, Front to Back Airflow - AFO

Fan Tray 6  
user@device>

Fan Tray, Front to Back Airflow - AFO



**NOTE:** You must remove the fan module to read the fan serial number from the serial number ID label. The fan module serial number cannot be viewed through the CLI. **Fan Tray 2** refers to the third fan module from the left, counting from 0.

## Locate the Chassis Serial Number ID Label on QFX5241-32OD Switch

You can find the chassis serial number in either the `show chassis hardware` command output or physically on the top of the QFX5241-32OD switch. See [Figure 66 on page 125](#).

**Figure 66: Location of the Serial Number ID Label on a QFX5241-32OD Switch**

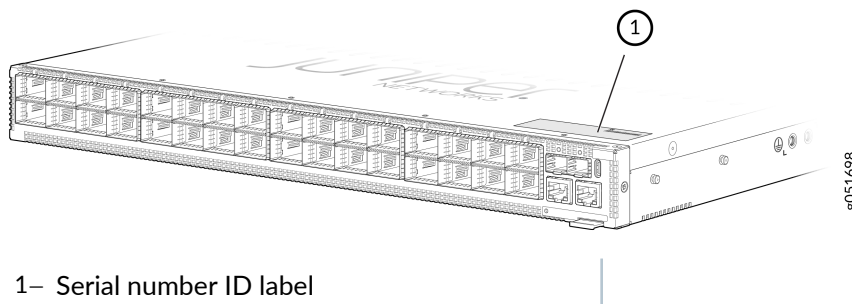

1– Serial number ID label

## Locate the Serial Number ID Labels on FRUs in a QFX5241-32OD Switch

The QFX5241-32OD switch contains Field Replaceable Units (FRUs) such as Power Supply Units (PSUs) and fan modules. To identify the serial number on these components, you must remove them from the switch chassis.

- AC power supply unit (PSU)—The serial number ID label is on the top of the AC PSU.

Figure 67: Serial Number ID Label on QFX5241-32OD AC PSU

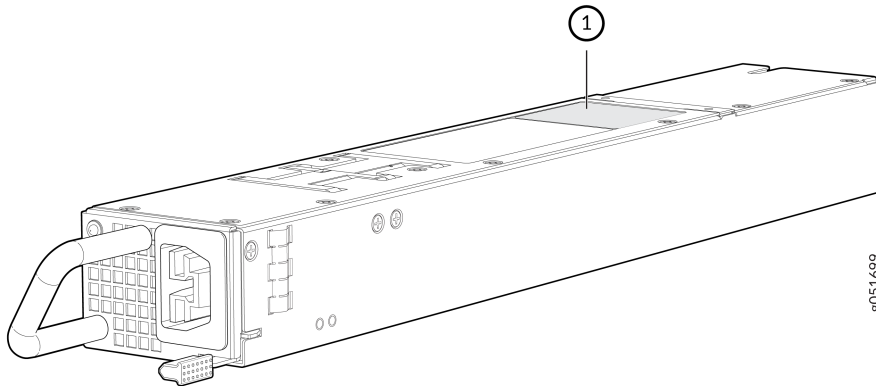

1– Serial number ID label

- Fan module—The serial number ID label is on the top of the fan module for a QFX5241-32OD switch.

Figure 68: Serial Number ID Label on QFX5241-32OD Fan Module

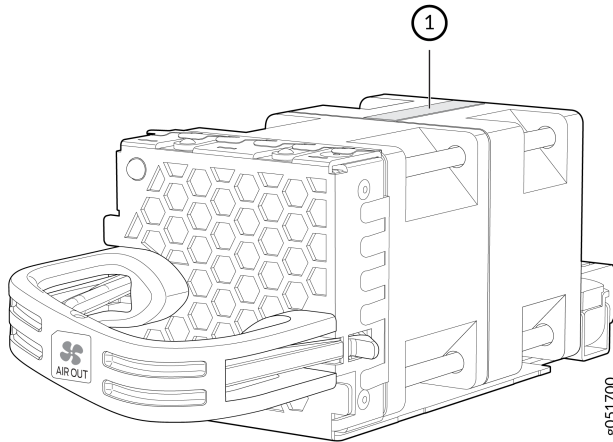

1– Serial number ID label

## Remove the Solid-State Drives for RMA on a QFX5241-32OD Switch

The QFX5241-32OD switch has two SSDs that store the software images, system logs, and the configuration files. Before returning a chassis to Juniper Networks as part of a Return Material

Authorization (RMA), you have the option to remove the SSDs and to dispose the SSDs according to your own company's security procedures. Before you begin this procedure, ensure you have the following tools:

- ESD grounding strip (not provided)
- Phillips screwdriver, number 2

Use this optional procedure to remove the drives from the QFX5241-32OD switch after the device has shut down and you've removed it from the rack or cabinet. The SSD doors are located on the top of the QFX5241-32OD switch.

1. Wrap and fasten one end of the ESD grounding strap around your bare wrist, and connect the other end to a site ESD point.
2. Place the device on a firm surface such as a workbench or a table with the SSD doors facing up.
3. Use the Phillips screwdriver to remove the three flat-head screws from each door on the top of the device.

**Figure 69: Remove Screws on SSD Doors in QFX5241-32OD Switch**

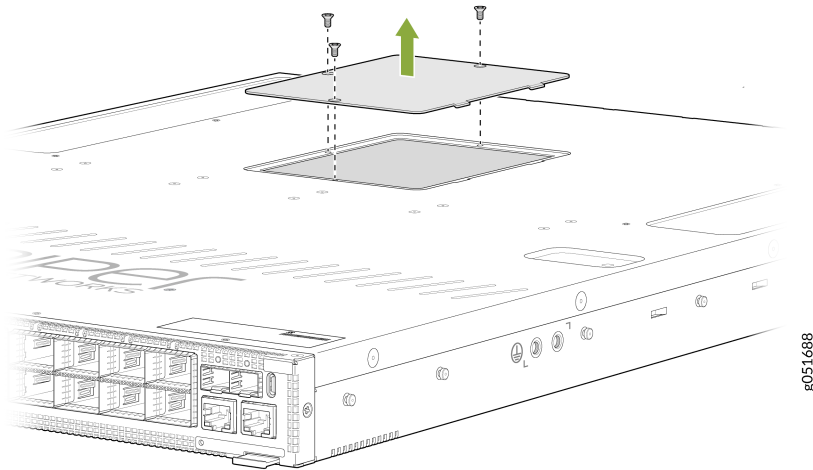

4. Remove the doors and set aside the screws.
5. Use the Phillips screwdriver to remove the screw on one of the SSDs and set it aside.

**Figure 70: Remove the Screw and Lift the SSD Out**

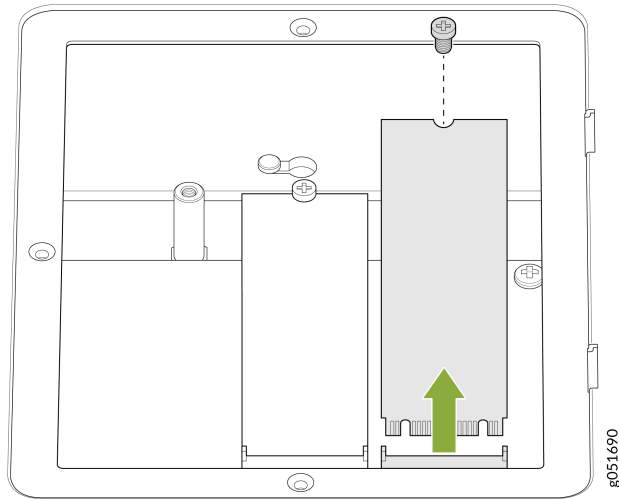

6. Lift the end farthest from the connector and remove from the SSD slot. Repeat Step 5 and Step 6 for the second SSD.
7. Replace the screws and hand-tighten the screws using the Phillips screwdriver.
8. Replace the SSD doors and the six flat-head screws.

**Figure 71: Replace the SSD Doors**

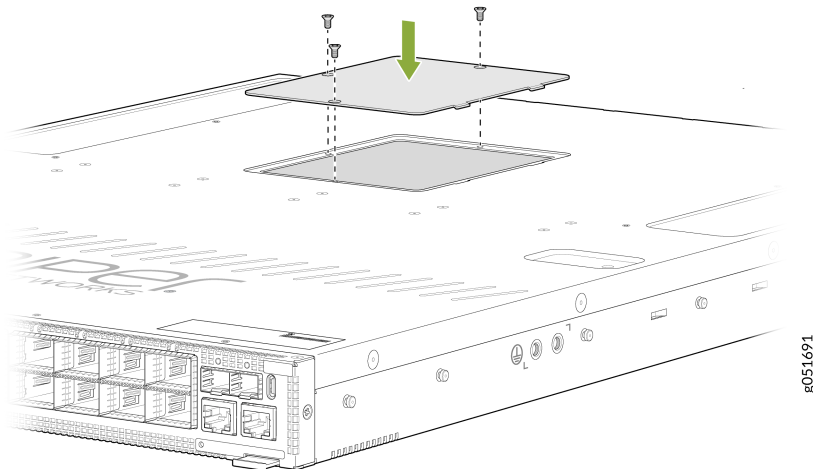

9. Hand-tighten the screws using the Phillips screwdriver.
10. Dispose of the SSDs according to your site security procedures.

## How to Return a Hardware Component to Juniper Networks, Inc.

If a hardware component fails, you need to contact Juniper Networks, Inc. to obtain a Return Material Authorization (RMA) number. This number is used to track the returned material at the factory and to return repaired or new components to the customer as needed.



**NOTE:** Do not return any component to Juniper Networks, Inc. unless you have first obtained an RMA number. Juniper Networks, Inc. reserves the right to refuse shipments that do not have an RMA. Refused shipments are returned to the customer by collect freight.

For more information about return and repair policies, see the customer support webpage at <https://support.juniper.net/support/>.

For product problems or technical support issues, contact the Juniper Networks Technical Assistance Center (JTAC) by using the Service Request Manager link at <https://support.juniper.net/support/> or at 1-888-314-JTAC (within the United States) or 1-408-745-9500 (from outside the United States).

To return a defective hardware component:

1. Determine the part number and serial number of the defective component.
2. Obtain an RMA number from the Juniper Networks Technical Assistance Center (JTAC). You can send e-mail or telephone as described above.
3. Provide the following information in your e-mail message or during the telephone call:
  - Part number and serial number of component
  - Your name, organization name, telephone number, and fax number
  - Description of the failure
4. The support representative validates your request and issues an RMA number for return of the component.
5. Pack the component for shipment.

## Guidelines for Packing Hardware Components for Shipment

To pack and ship individual components:

- When you return components, make sure that they are adequately protected with packing materials and packed so that the pieces are prevented from moving around inside the carton.
- Use the original shipping materials if they are available.

- Place individual components in antistatic bags.
- Write the RMA number on the exterior of the box to ensure proper tracking.



**CAUTION:** Do not stack any of the hardware components.

## Pack QFX5241-32OD Switch or Component for Shipping

### IN THIS SECTION

- [Pack a QFX5241-32OD Switch for Shipping | 130](#)
- [Pack QFX5241-32OD Components for Shipping | 131](#)

If you are returning a QFX5241-32OD switch or one of its components to Juniper Networks for repair or replacement, pack the item as described in this topic.

Before you pack a QFX5241-32OD switch or its components:

- Ensure that you have taken the necessary precautions to prevent electrostatic discharge (ESD) damage.
- Retrieve the original shipping carton and packing materials. Contact your JTAC representative if you do not have these materials, to learn about approved packing materials. See "[Contact Customer Support to Obtain a Return Material Authorization](#)" on [page 122](#) .

Ensure that you have the following parts and tools available:

- ESD grounding strap.
- Antistatic bag, one for each component.
- If you are returning the chassis, an appropriate screwdriver for the mounting screws used on your rack or cabinet.

### Pack a QFX5241-32OD Switch for Shipping

To pack a QFX5241-32OD switch for shipping:

1. Power off the switch and remove the power cables. See ["Power Off a QFX5241-32OD Switch" on page 111](#).
2. Remove the cables that connect the QFX5241-32OD switch to all external devices.
3. Remove all field-replaceable units (FRUs) from the switch.
4. Have one person support the weight of the switch while another person unscrews and removes the mounting screws.
5. Remove the switch from the rack and place the switch in a large antistatic bag.
6. Place the switch in the shipping carton.
7. Place the packing foam on top of and around the switch.
8. If you are returning accessories or FRUs with the switch, pack them as instructed in ["Pack QFX5241-32OD Components for Shipping" on page 131](#).
9. Replace the accessory box on top of the packing foam.
10. Close the top of the cardboard shipping box and seal it with packing tape.
11. Write the RMA number on the exterior of the box to ensure proper tracking.

## Pack QFX5241-32OD Components for Shipping



**CAUTION:** Do not stack switch components. Return individual components in separate boxes if they do not fit together on one level in the shipping box.

To pack and ship QFX5241-32OD components:

- Place individual FRUs in antistatic bags.
- Ensure that the components are adequately protected with packing materials and packed so that the pieces are prevented from moving around inside the carton.
- Close the top of the cardboard shipping box and seal it with packing tape.
- Write the RMA number on the exterior of the box to ensure proper tracking.

# 8

CHAPTER

## Safety and Compliance Information

---

### IN THIS CHAPTER

- [Safety Information | 133](#)
  - [Compliance Statements for EMC Requirements | 133](#)
  - [Compliance Standards for QFX5241-32OD Switches | 135](#)
-

# Safety Information

The [Juniper Networks Safety Guide](#) provides general safety information and guidelines for all Juniper Networks products. Follow the guidelines provided in the guide to reduce the likelihood of personal injury, equipment damage, and damage to surrounding areas.

Along with the information provided in the Juniper Networks Safety Guide, you must read and understand the QFX5241-32OD-specific safety information provided in this hardware guide.

## Compliance Statements for EMC Requirements

### IN THIS SECTION

- [Canada | 133](#)
- [European Community | 133](#)
- [Israel | 134](#)
- [Japan | 134](#)
- [United States | 134](#)

### Canada

CAN ICES-3 (A)/NMB-3(A)

### European Community

This is a Class A product. In a domestic environment, this product might cause radio interference in which case the user might be required to take adequate measures.

## Israel

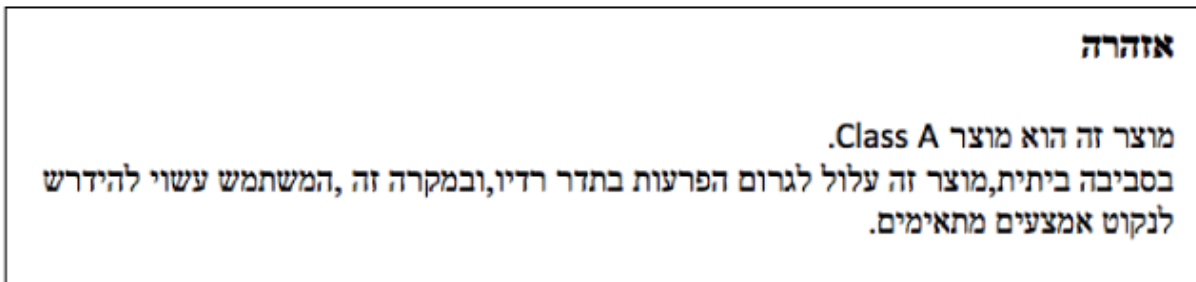

Translation from Hebrew—Warning: This product is Class A. In residential environments, the product might cause radio interference, and in such a situation, the user might be required to take adequate measures.

## Japan

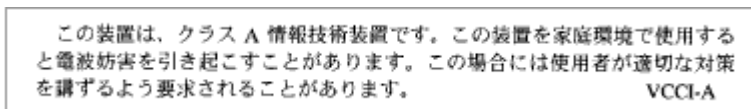

The preceding translates as follows:

This is a Class A product based on the standard of the Voluntary Control Council for Interference by Information Technology Equipment (VCCI). If this product is used near a radio or television receiver in a domestic environment, it might cause radio interference. Install and use the equipment according to the instruction manual. VCCI-A.

## United States

The hardware equipment has been tested and found to comply with the limits for a Class A digital device, pursuant to Part 15 of the FCC Rules. These limits are designed to provide reasonable protection against harmful interference when the equipment is operated in a commercial environment. This equipment generates, uses, and can radiate radio frequency energy and, if not installed and used in accordance with the instruction manual, might cause harmful interference to radio communications. Operation of this equipment in a residential area is likely to cause harmful interference in which case the user will be required to correct the interference at his own expense.

# Compliance Standards for QFX5241-32OD Switches

## IN THIS SECTION

- [Compliance Statement for Argentina | 136](#)

The QFX5241-32OD switches comply with the following standards:

- Safety
  - UL 60950-1:2007 R10.14 Information Technology Equipment
  - CAN/CSA-C22.2 No. 60950-1-07, Amd 1:2011, Amd 2:2014 Information Technology Equipment
  - IEC 62368-1:2014 (2nd Edition) Audio/Video, Information and Communication Technology Equipment (Include all country deviation)
  - IEC 62368-1:2018 (3rd Edition) Audio/Video, Information and Communication Technology Equipment (Include all country deviation)
  - EN 62368-1:2014+A11:2017 Audio/Video, Information and Communication Technology Equipment
  - UL/CSA 62368-1:2019 (3rd edition) Audio/Video, Information and Communication Technology Equipment
  - IEC/EN 60825-1 Safety of Laser Products – Part 1: Equipment classification and requirements
- EMC
  - FCC 47 CFR Part 15
  - ICES-003 / ICES-GEN
  - BS EN 55032
  - BS EN 55035
  - EN 300 386 V1.6.1
  - EN 300 386 V2.2.1
  - BS EN 300 386

- EN 55032
- CISPR 32
- EN 55035
- CISPR 35
- IEC/EN 61000 Series
- IEC/EN 61000-3-2
- IEC/EN 61000-3-3
- AS/NZS CISPR 32
- VCCI-CISPR 32
- BSMI CNS 15936
- KS C 9835 (Old KN 35)
- KS C 9832 (Old KN 32)
- KS C 9610
- BS EN 61000 Series

## **Compliance Statement for Argentina**

EQUIPO DE USO IDÓNEO.